

Ranger Excavating, LP

Aboveground Storage Tank (AST) Plan  
Application

Rattlesnake Ranch Quarry

8880 Old 195

Florence, Texas 76527

Williamson County

Submitted to: TCEQ Region 11, Austin

Prepared By:



Boerne, Texas

830-249-8284

Date: February 2024

Project No. 11260-005

-AK-



Signature: Andrea Kidd

Andrea Kidd, P.E. - License No. 132541

TX PE Firm No. 4524

Date: 2/22/2024

# Aboveground Storage Tank Facility Plan Checklist

- **Edwards Aquifer Application Cover Page (TCEQ-20705)**
- **General Information Form (TCEQ-0587)**
  - Attachment A - Road Map
  - Attachment B - USGS / Edwards Recharge Zone Map
  - Attachment C - Project Description
- **Geologic Assessment Form (TCEQ-0585)**
  - Attachment A - Geologic Assessment Table (TCEQ-0585-Table)
  - Attachment B - Stratigraphic Column
  - Attachment C - Site Geology
  - Attachment D - Site Geologic Map(s)
- **Aboveground Storage Tank Facility Plan (TCEQ-0575)**
  - Attachment A - Alternative Methods of Secondary Containment (if proposed)
  - Attachment B - Scaled Drawing(s) of Containment Structure
  - Attachment C - Exception to the Geologic Assessment (if requested)
  - Attachment D - Spill and Overfill Control
  - Attachment E - Response Actions to Spills
  - Site Plan
- **Temporary Stormwater Section (TCEQ-0602)**
  - Attachment A - Spill Response Actions
  - Attachment B - Potential Sources of Contamination
  - Attachment C - Sequence of Major Activities
  - Attachment D - Temporary Best Management Practices and Measures
  - Attachment E - Request to Temporarily Seal a Feature (if requested)
  - Attachment F - Structural Practices
  - Attachment G - Drainage Area Map
  - Attachment H - Temporary Sediment Pond(s) Plans and Calculations
  - Attachment I - Inspection and Maintenance for BMPs
  - Attachment J - Schedule of Interim and Permanent Soil Stabilization Practices
- **Agent Authorization Form (TCEQ-0599), if application submitted by agent**
- **Application Fee Form (TCEQ-0574)**
- **Check Payable to the “Texas Commission on Environmental Quality”**
- **Core Data Form (TCEQ-10400)**

# Texas Commission on Environmental Quality

## Edwards Aquifer Application Cover Page

---

### Our Review of Your Application

**The Edwards Aquifer Program staff conducts an administrative and technical review of all applications. The turnaround time for administrative review can be up to 30 days as outlined in 30 TAC 213.4(e). Generally administrative completeness is determined during the intake meeting or within a few days of receipt. The turnaround time for technical review of an administratively complete Edwards Aquifer application is 90 days as outlined in 30 TAC 213.4(e). Please know that the review and approval time is directly impacted by the quality and completeness of the initial application that is received. In order to conduct a timely review, it is imperative that the information provided in an Edwards Aquifer application include final plans, be accurate, complete, and in compliance with [30 TAC 213](#).**

### Administrative Review

1. [Edwards Aquifer applications](#) must be deemed administratively complete before a technical review can begin. To be considered administratively complete, the application must contain completed forms and attachments, provide the requested information, and meet all the site plan requirements. The submitted application and plan sheets should be final plans. Please submit one full-size set of plan sheets with the original application, and half-size sets with the additional copies.

To ensure that all applicable documents are included in the application, the program has developed tools to guide you and web pages to provide all forms, checklists, and guidance. Please visit the below website for assistance: <http://www.tceq.texas.gov/field/eapp>.

2. This Edwards Aquifer Application Cover Page form (certified by the applicant or agent) must be included in the application and brought to the administrative review meeting.
3. Administrative reviews are scheduled with program staff who will conduct the review. Applicants or their authorized agent should call the appropriate regional office, according to the county in which the project is located, to schedule a review. The average meeting time is one hour.
4. In the meeting, the application is examined for administrative completeness. Deficiencies will be noted by staff and emailed or faxed to the applicant and authorized agent at the end of the meeting, or shortly after. Administrative deficiencies will cause the application to be deemed incomplete and returned.

An appointment should be made to resubmit the application. The application is re-examined to ensure all deficiencies are resolved. The application will only be deemed administratively complete when all administrative deficiencies are addressed.

5. If an application is received by mail, courier service, or otherwise submitted without a review meeting, the administrative review will be conducted within 30 days. The applicant and agent will be contacted with the results of the administrative review. If the application is found to be administratively incomplete, it can be retrieved from the regional office or returned by regular mail. If returned by mail, the regional office may require arrangements for return shipping.
6. If the geologic assessment was completed before October 1, 2004 and the site contains “possibly sensitive” features, the assessment must be updated in accordance with the *Instructions to Geologists* (TCEQ-0585 Instructions).

### Technical Review

1. When an application is deemed administratively complete, the technical review period begins. The regional office will distribute copies of the application to the identified affected city, county, and groundwater conservation district whose jurisdiction includes the subject site. These entities and the public have 30 days to provide comments on the application to the regional office. All comments received are reviewed by TCEQ.
2. A site assessment is usually conducted as part of the technical review, to evaluate the geologic assessment and observe existing site conditions. The site must be accessible to our staff. The site boundaries should be

clearly marked, features identified in the geologic assessment should be flagged, roadways marked and the alignment of the Sewage Collection System and manholes should be staked at the time the application is submitted. If the site is not marked the application may be returned.

3. We evaluate the application for technical completeness and contact the applicant and agent via Notice of Deficiency (NOD) to request additional information and identify technical deficiencies. There are two deficiency response periods available to the applicant. There are 14 days to resolve deficiencies noted in the first NOD. If a second NOD is issued, there is an additional 14 days to resolve deficiencies. If the response to the second notice is not received, is incomplete or inadequate, or provides new information that is incomplete or inadequate, the application must be withdrawn or will be denied. Please note that because the technical review is underway, whether the application is withdrawn or denied **the application fee will be forfeited.**
4. The program has 90 calendar days to complete the technical review of the application. If the application is technically adequate, such that it complies with the Edwards Aquifer rules, and is protective of the Edwards Aquifer during and after construction, an approval letter will be issued. Construction or other regulated activity may not begin until an approval is issued.

### Mid-Review Modifications

It is important to have final site plans prior to beginning the permitting process with TCEQ to avoid delays.

Occasionally, circumstances arise where you may have significant design and/or site plan changes after your Edwards Aquifer application has been deemed administratively complete by TCEQ. This is considered a “Mid-Review Modification”. Mid-Review Modifications may require redistribution of an application that includes the proposed modifications for public comment.

If you are proposing a Mid-Review Modification, two options are available:

- If the technical review has begun your application can be denied/withdrawn, your fees will be forfeited, and the plan will have to be resubmitted.
- TCEQ can continue the technical review of the application as it was submitted, and a modification application can be submitted at a later time.

If the application is denied/withdrawn, the resubmitted application will be subject to the administrative and technical review processes and will be treated as a new application. The application will be redistributed to the affected jurisdictions.

Please contact the regional office if you have questions. If your project is located in Williamson, Travis, or Hays County, contact TCEQ’s Austin Regional Office at 512-339-2929. If your project is in Comal, Bexar, Medina, Uvalde, or Kinney County, contact TCEQ’s San Antonio Regional Office at 210-490-3096

Please fill out all required fields below and submit with your application.

<b>1. Regulated Entity Name:</b> Rattlesnake Ranch Quarry				<b>2. Regulated Entity No.:</b> 111875878					
<b>3. Customer Name:</b> Ranger Excavation, LP				<b>4. Customer No.:</b> 602783037					
<b>5. Project Type:</b> (Please circle/check one)	New		Modification		Extension	Exception			
<b>6. Plan Type:</b> (Please circle/check one)	WPAP	CZP	SCS	UST	AST	EX P	EXT	Technical Clarification	Optional Enhanced Measures
<b>7. Land Use:</b> (Please circle/check one)	Residential		Non-residential			<b>8. Site (acres):</b>		163	
<b>9. Application Fee:</b>	\$3900		<b>10. Permanent BMP(s):</b>			N/A			
<b>11. SCS (Linear Ft.):</b>	N/A		<b>12. AST/UST (No. Tanks):</b>			6			
<b>13. County:</b>	Williamson		<b>14. Watershed:</b>			Berry Creek			

# Application Distribution

Instructions: Use the table below to determine the number of applications required. One original and one copy of the application, plus additional copies (as needed) for each affected incorporated city, county, and groundwater conservation district are required. Linear projects or large projects, which cross into multiple jurisdictions, can require additional copies. Refer to the “Texas Groundwater Conservation Districts within the EAPP Boundaries” map found at:

[http://www.tceq.texas.gov/assets/public/compliance/field\\_ops/eapp/EAPP%20GWCD%20map.pdf](http://www.tceq.texas.gov/assets/public/compliance/field_ops/eapp/EAPP%20GWCD%20map.pdf)

For more detailed boundaries, please contact the conservation district directly.

<b>Austin Region</b>			
<b>County:</b>	<b>Hays</b>	<b>Travis</b>	<b>Williamson</b>
Original (1 req.)	—	—	<u>X</u>
Region (1 req.)	—	—	<u>X</u>
County(ies)	—	—	<u>X</u>
Groundwater Conservation District(s)	<input type="checkbox"/> Edwards Aquifer Authority <input type="checkbox"/> Barton Springs/ Edwards Aquifer <input type="checkbox"/> Hays Trinity <input type="checkbox"/> Plum Creek	<input type="checkbox"/> Barton Springs/ Edwards Aquifer	NA
City(ies) Jurisdiction	<input type="checkbox"/> Austin <input type="checkbox"/> Buda <input type="checkbox"/> Dripping Springs <input type="checkbox"/> Kyle <input type="checkbox"/> Mountain City <input type="checkbox"/> San Marcos <input type="checkbox"/> Wimberley <input type="checkbox"/> Woodcreek	<input type="checkbox"/> Austin <input type="checkbox"/> Bee Cave <input type="checkbox"/> Pflugerville <input type="checkbox"/> Rollingwood <input type="checkbox"/> Round Rock <input type="checkbox"/> Sunset Valley <input type="checkbox"/> West Lake Hills	<input type="checkbox"/> Austin <input type="checkbox"/> Cedar Park <input type="checkbox"/> Florence <input checked="" type="checkbox"/> Georgetown <input type="checkbox"/> Jerrell <input type="checkbox"/> Leander <input type="checkbox"/> Liberty Hill <input type="checkbox"/> Pflugerville <input type="checkbox"/> Round Rock

<b>San Antonio Region</b>					
<b>County:</b>	<b>Bexar</b>	<b>Comal</b>	<b>Kinney</b>	<b>Medina</b>	<b>Uvalde</b>
Original (1 req.)	—	—	—	—	—
Region (1 req.)	—	—	—	—	—
County(ies)	—	—	—	—	—
Groundwater Conservation District(s)	<input type="checkbox"/> Edwards Aquifer Authority <input type="checkbox"/> Trinity-Glen Rose	<input type="checkbox"/> Edwards Aquifer Authority	<input type="checkbox"/> Kinney	<input type="checkbox"/> EAA <input type="checkbox"/> Medina	<input type="checkbox"/> EAA <input type="checkbox"/> Uvalde
City(ies) Jurisdiction	<input type="checkbox"/> Castle Hills <input type="checkbox"/> Fair Oaks Ranch <input type="checkbox"/> Helotes <input type="checkbox"/> Hill Country Village <input type="checkbox"/> Hollywood Park <input type="checkbox"/> San Antonio (SAWS) <input type="checkbox"/> Shavano Park	<input type="checkbox"/> Bulverde <input type="checkbox"/> Fair Oaks Ranch <input type="checkbox"/> Garden Ridge <input type="checkbox"/> New Braunfels <input type="checkbox"/> Schertz	NA	<input type="checkbox"/> San Antonio ETJ (SAWS)	NA

I certify that to the best of my knowledge, that the application is complete and accurate. This application is hereby submitted to TCEQ for administrative review and technical review.

Andrea Kidd, PE

TX License No. 132541 | Firm No. 4524



Print Name of Engineer/Authorized Agent

*Andrea Kidd*

2/22/2024

Signature of Engineer/Authorized Agent

Date

**\*\*FOR TCEQ INTERNAL USE ONLY\*\***

Date(s) Reviewed:		Date Administratively Complete:	
Received From:		Correct Number of Copies:	
Received By:		Distribution Date:	
EAPP File Number:		Complex:	
Admin. Review(s) (No.):		No. AR Rounds:	
Delinquent Fees (Y/N):		Review Time Spent:	
Lat./Long. Verified:		SOS Customer Verification:	
Agent Authorization Complete/Notarized (Y/N):		Fee Check:	Payable to TCEQ (Y/N):
Core Data Form Complete (Y/N):			Signed (Y/N):
Core Data Form Incomplete Nos.:			Less than 90 days old (Y/N):

# General Information Form

## Texas Commission on Environmental Quality

For Regulated Activities on the Edwards Aquifer Recharge and Transition Zones and Relating to 30 TAC §213.4(b) & §213.5(b)(2)(A), (B) Effective June 1, 1999

**To ensure that the application is administratively complete, confirm that all fields in the form are complete, verify that all requested information is provided, consistently reference the same site and contact person in all forms in the application, and ensure forms are signed by the appropriate party.**

**Note: Including all the information requested in the form and attachments contributes to more streamlined technical reviews.**

## Signature

To the best of my knowledge, the responses to this form accurately reflect all information requested concerning the proposed regulated activities and methods to protect the Edwards Aquifer. This **General Information Form** is hereby submitted for TCEQ review. The application was prepared by:

Print Name of Customer/Agent: Andrea Kidd, P.E.

Texas License No. 132541 | Firm No. 4524

Date: 2/22/2024

Signature of Engineer/Agent:

*Andrea Kidd*



## Project Information

1. Regulated Entity Name: Rattlesnake Ranch Quarry
2. County: Williamson County
3. Stream Basin: Berry Creek
4. Groundwater Conservation District (If applicable): N/A

5. Edwards Aquifer Zone:

- Recharge Zone  
 Contributing Zone

Transition Zone

6. Plan Type:

- WPAP  
 SCS  
 Modification

- AST  
 UST  
 Exception Request

7. Customer (Applicant):

Contact Person: Hamilton McRae

Entity: Ranger Excavating, LP.

Mailing Address: 5222 Thunder Creek Rd, Suite B1

City, State: Austin, TX

Zip: 78759

Telephone: 512-331-5551

FAX: 512-343-9618

Email Address: hamilton.mcrae@austingeologic.com

8. Agent/Representative (If any):

Contact Person: Andrea Kidd, P.E.

Entity: Westward Environmental, Inc.

Mailing Address: PO Box 2205

City, State: Boerne, TX

Zip: 78006

Telephone: 830-249-8284

FAX: 830-249-0221

Email Address: akidd@westwardenv.com

9. Project Location:

- The project site is located inside the city limits of \_\_\_\_.
- The project site is located outside the city limits but inside the ETJ (extra-territorial jurisdiction) of City of Georgetown.
- The project site is not located within any city's limits or ETJ.

10.  The location of the project site is described below. The description provides sufficient detail and clarity so that the TCEQ's Regional staff can easily locate the project and site boundaries for a field investigation.

8880 Old 195, Florence, TX 76527. Located east of SH 195 and Old 195 (Rattlesnake Rd)

11.  **Attachment A – Road Map.** A road map showing directions to and the location of the project site is attached. The project location and site boundaries are clearly shown on the map.
12.  **Attachment B - USGS / Edwards Recharge Zone Map.** A copy of the official 7 ½ minute USGS Quadrangle Map (Scale: 1" = 2000') of the Edwards Recharge Zone is attached. The map(s) clearly show:
- Project site boundaries.
  - USGS Quadrangle Name(s).
  - Boundaries of the Recharge Zone (and Transition Zone, if applicable).
  - Drainage path from the project site to the boundary of the Recharge Zone.
13.  **The TCEQ must be able to inspect the project site or the application will be returned.** Sufficient survey staking is provided on the project to allow TCEQ regional staff to locate



the boundaries and alignment of the regulated activities and the geologic or manmade features noted in the Geologic Assessment.

Survey staking will be completed by this date: 10/23/2023

14.  **Attachment C – Project Description.** Attached at the end of this form is a detailed narrative description of the proposed project. The project description is consistent throughout the application and contains, at a minimum, the following details:

- Area of the site
- Offsite areas
- Impervious cover
- Permanent BMP(s)
- Proposed site use
- Site history
- Previous development
- Area(s) to be demolished

15. Existing project site conditions are noted below:

- Existing commercial site
- Existing industrial site
- Existing residential site
- Existing paved and/or unpaved roads
- Undeveloped (Cleared)
- Undeveloped (Undisturbed/Uncleared)
- Other: \_\_\_\_\_

### ***Prohibited Activities***

16.  I am aware that the following activities are prohibited on the Recharge Zone and are not proposed for this project:

- (1) Waste disposal wells regulated under 30 TAC Chapter 331 of this title (relating to Underground Injection Control);
- (2) New feedlot/concentrated animal feeding operations, as defined in 30 TAC §213.3;
- (3) Land disposal of Class I wastes, as defined in 30 TAC §335.1;
- (4) The use of sewage holding tanks as parts of organized collection systems; and
- (5) New municipal solid waste landfill facilities required to meet and comply with Type I standards which are defined in §330.41(b), (c), and (d) of this title (relating to Types of Municipal Solid Waste Facilities).
- (6) New municipal and industrial wastewater discharges into or adjacent to water in the state that would create additional pollutant loading.

17.  I am aware that the following activities are prohibited on the Transition Zone and are not proposed for this project:

- (1) Waste disposal wells regulated under 30 TAC Chapter 331 (relating to Underground Injection Control);
- (2) Land disposal of Class I wastes, as defined in 30 TAC §335.1; and
- (3) New municipal solid waste landfill facilities required to meet and comply with Type I standards which are defined in §330.41 (b), (c), and (d) of this title.

### ***Administrative Information***

18. The fee for the plan(s) is based on:

- For a Water Pollution Abatement Plan or Modification, the total acreage of the site where regulated activities will occur.
- For an Organized Sewage Collection System Plan or Modification, the total linear footage of all collection system lines.
- For a UST Facility Plan or Modification or an AST Facility Plan or Modification, the total number of tanks or piping systems.
- A request for an exception to any substantive portion of the regulations related to the protection of water quality.
- A request for an extension to a previously approved plan.

19.  Application fees are due and payable at the time the application is filed. If the correct fee is not submitted, the TCEQ is not required to consider the application until the correct fee is submitted. Both the fee and the Edwards Aquifer Fee Form have been sent to the Commission's:

- TCEQ cashier **ePay**
- Austin Regional Office (for projects in Hays, Travis, and Williamson Counties)
- San Antonio Regional Office (for projects in Bexar, Comal, Kinney, Medina, and Uvalde Counties)

20.  Submit one (1) original and one (1) copy of the application, plus additional copies as needed for each affected incorporated city, groundwater conservation district, and county in which the project will be located. The TCEQ will distribute the additional copies to these jurisdictions. The copies must be submitted to the appropriate regional office.

21.  No person shall commence any regulated activity until the Edwards Aquifer Protection Plan(s) for the activity has been filed with and approved by the Executive Director.

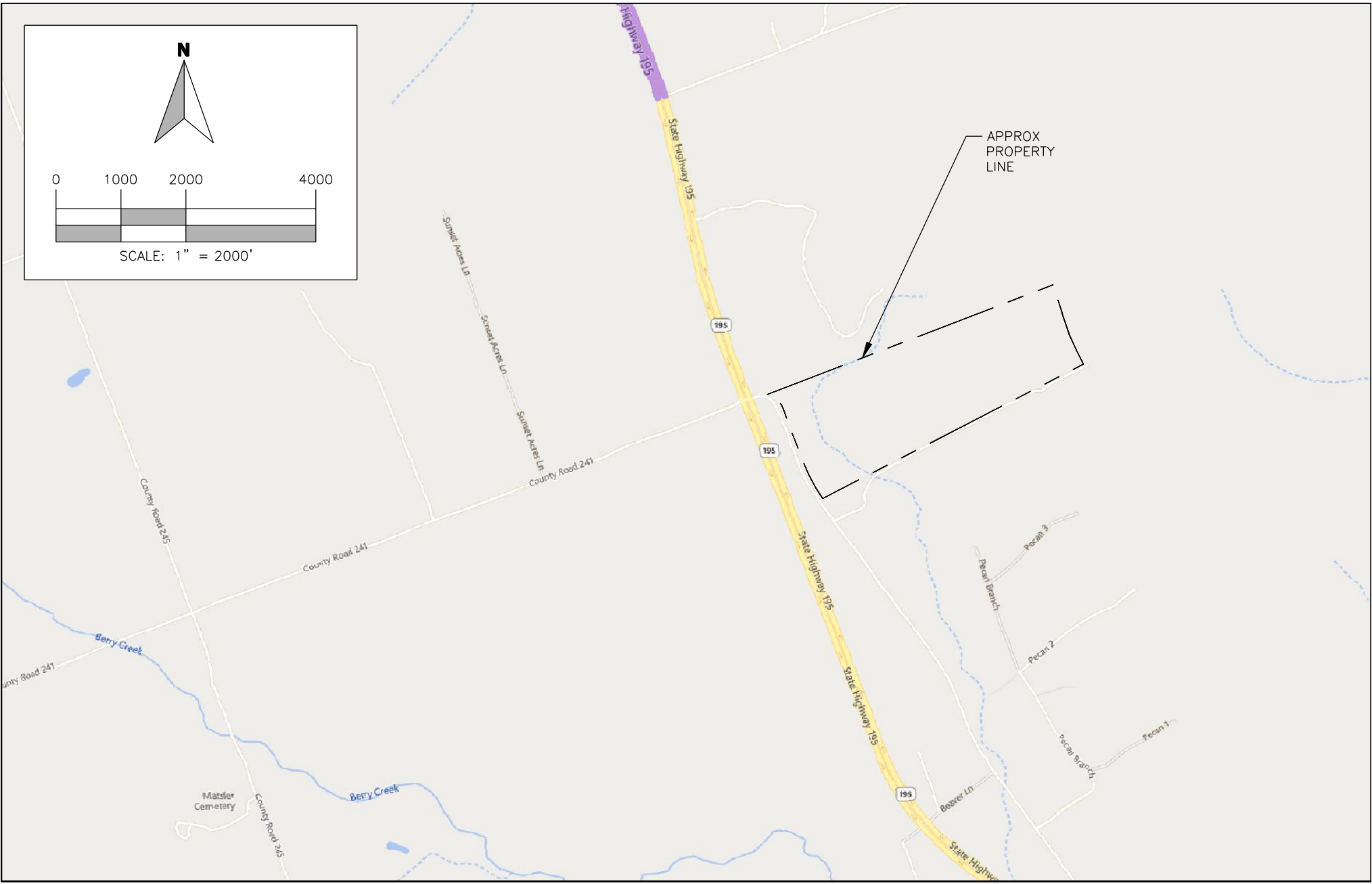
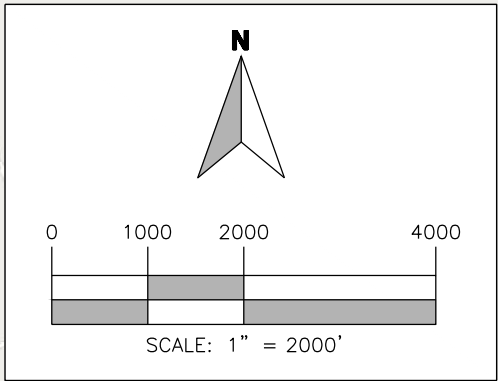

SHEET NO.: **1**  
OF 1

IMAGE: BING MAPS	
ISSUE DATE:	01/08/2024
DRAWN BY:	AK
CHECKED BY:	CJF
SCALE: 1" =	2000'
JOB NO.:	11260-005

<b>ROAD MAP</b>			
RATTLESNAKE RANCH QUARRY – AST PLAN			
RANGER EXCAVATING, LP			
FLORENCE, WILLIAMSON COUNTY, TEXAS			
REV.	DESCRIPTION	BY	DATE

THIS PRODUCT IS FOR INFORMATIONAL PURPOSES AND MAY NOT HAVE BEEN PREPARED FOR OR BE SUITABLE FOR LEGAL, ENGINEERING, OR SURVEYING PURPOSES. IT DOES NOT REPRESENT AN ON-THE-GROUND SURVEY AND REPRESENTS ONLY THE APPROXIMATE RELATIVE LOCATION OF PROPERTY BOUNDARIES.

**WESTWARD**  
Environmental. Engineering. Natural Resources.

P.O. Box 2205 Boerne, Texas 78006  
(830) 249-8284 Fax: (830) 249-0221  
TBPE REG. NO.: F-4524  
TBPG REG. NO.: 50112

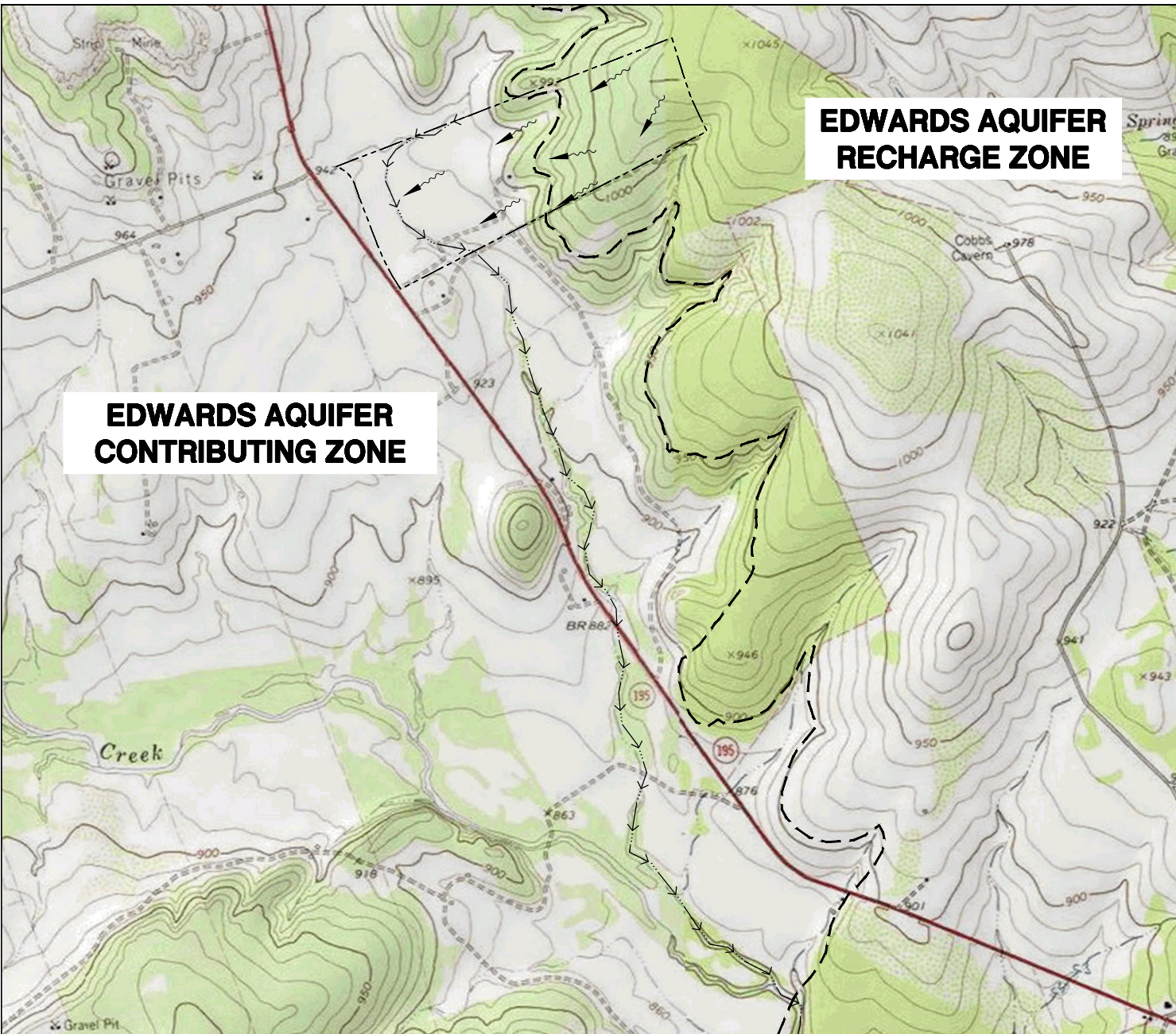

SCALE: 1" = 2,000

**LEGEND**

- PROPERTY LINE
- >->->- FLOW PATH
- EDWARDS ZONE BOUNDARY
- ~> FLOW ARROW

NOTE:

USGS TOPO 7.5-MINUTE MAP FOR FLORENCE, TEXAS AND COBBS CAVERN, TEXAS

SHEET NO.:  <b>1</b>  OF 1	IMAGE: USGS Topo 7.5-Minute Maps	
	ISSUE DATE:	01/24/2024
	DRAWN BY:	AK
	CHECKED BY:	CJF
	SCALE: 1" =	2,000'
	JOB NO.:	11260-005

<b>USGS &amp; EDWARDS AQUIFER</b> RATTLESNAKE RANCH QUARRY – AST Plan RANGER EXCAVATING, LP FLORENCE, WILLIAMSON COUNTY, TX			
REV.	DESCRIPTION	BY	DATE

THIS PRODUCT IS FOR INFORMATIONAL PURPOSES AND MAY NOT HAVE BEEN PREPARED FOR OR BE SUITABLE FOR LEGAL, ENGINEERING, OR SURVEYING PURPOSES. IT DOES NOT REPRESENT AN ON-THE-GROUND SURVEY AND REPRESENTS ONLY THE APPROXIMATE RELATIVE LOCATION OF PROPERTY BOUNDARIES.

**WESTWARD**

Environmental. Engineering. Natural Resources.

P.O. Box 2205 Boerne, Texas 78006  
 (830) 249-8284 Fax: (830) 249-0221  
 TBPE REG. NO.: F-4524  
 TBPB REG. NO.: 50112

**Ranger Excavating, LP  
Rattlesnake Ranch Quarry**

**General Information Form (TCEQ-0587)  
Attachment C**

**Project Description**

This Aboveground Storage Tank (AST) Plan has been prepared on behalf of Ranger Excavating, LP, for the proposed Rattlesnake Ranch Quarry (Site). This approximately 163-acre site, located in Williamson County, Florence, Texas, is to be developed for a new limestone quarrying operation. The site is located over the Edwards Aquifer with the east portion over the Recharge Zone and the west portion over the Contributing Zone. A Water Pollution Abatement Plan (WPAP) has been submitted for this site on 12/19/2023 (EAPP ID 11003852).

The majority of the 163-acre site is largely undeveloped, with the exception of a residence structure, unpaved ranch roads, well sites, and various agricultural storage buildings.

This AST Plan proposes the following storage tanks:

AST #	Capacity (gals)	Contents	Tank Type
1	10,000	Diesel	Double-walled steel
2	10,000	Diesel	Double-walled steel
3	1,000	Used Oil	Double-walled steel
4	515	Transmission Fluid	Double-walled steel
5	515	Maintenance Oil	Double-walled steel
6	515	Maintenance Oil	Double-walled steel

Refueling will continue to occur over compacted base material. ASTs #3 - #6 will be located inside the proposed future shop building.

The drainage patterns of the site and soil stabilization measures are covered in detail in the submitted WPAP application.

Trash generated on-site will be disposed of in a dumpster and handled by a licensed waste service provider.

Several of the attachments relating to stormwater BMPs (Temporary Stormwater Section Attachments C, D, E, F, G, H, I, and J) are not included with this project as they are addressed in the WPAP.

A geologic assessment (GA), dated December 15, 2023, is included in this report. The 163-acre tract is included in the GA. This GA identified twelve geologic features, however none of the features are classified as sensitive features. Two water wells are in the same well house near the existing residence; one is operational and one is proposed to be abandoned. Aboveground storage tanks will not be located within 150-foot of the existing water wells.

RANGER EXCAVATING, LP

GEOLOGIC ASSESSMENT

RATTLESNAKE RANCH QUARRY  
8880 OLD 195  
FLORENCE, TEXAS 76527  
WILLIAMSON COUNTY

Submitted to: TCEQ Region 11, Austin

Prepared By:



Boerne, Texas  
830-249-8284

Date: December 2023  
Project No. 11260-005  
-JG-

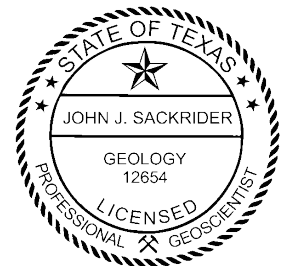

Signature: \_\_\_\_\_

John J. Sackrider, P.G. - License No. 12654  
TX PG Firm No. 50112

Date: 12/15/2023

# Article I. Geologic Assessment

## Texas Commission on Environmental Quality

For Regulated Activities on The Edwards Aquifer Recharge/transition Zones and Relating to 30 TAC §213.5(b)(3), Effective June 1, 1999

**To ensure that the application is administratively complete, confirm that all fields in the form are complete, verify that all requested information is provided, consistently reference the same site and contact person in all forms in the application, and ensure forms are signed by the appropriate party.**

**Note: Including all the information requested in the form and attachments contributes to more streamlined technical reviews.**

### Section 1.01 Signature

To the best of my knowledge, the responses to this form accurately reflect all information requested concerning the proposed regulated activities and methods to protect the Edwards Aquifer. My signature certifies that I am qualified as a geologist as defined by 30 TAC Chapter 213.

Print Name of Geologist:

Telephone: 830-249-8284

John J. Sackrider, P.G. #12654

Fax: 830-249-0221

Date: 12/15/2023

Representing: Westward Environmental, Inc., TBPB Registered Geoscience Firm 50012  
(Name of Company and TBPB or TBPE registration number)

Signature of Geologist:

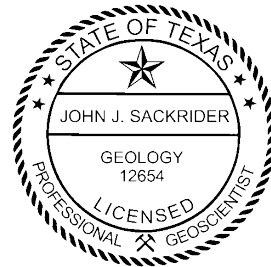
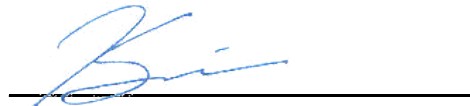

Regulated Entity Name: Rattlesnake Ranch Quarry

### Section 1.02 Project Information

1. Date(s) Geologic Assessment was performed: October 23-24, 2023

2. Type of Project:

WPAP  
 SCS

AST  
 UST

3. Location of Project:

Recharge Zone  
 Transition Zone  
 Contributing Zone within the Transition Zone

4.  **Attachment A - Geologic Assessment Table.** Completed Geologic Assessment Table (Form TCEQ-0585-Table) is attached.
5.  Soil cover on the project site is summarized in the table below and uses the SCS Hydrologic Soil Groups\* (Urban Hydrology for Small Watersheds, Technical Release No. 55, Appendix A, Soil Conservation Service, 1986). If there is more than one soil type on the project site, show each soil type on the site Geologic Map or a separate soils map.

**Article II. Table 1 - Soil Units, Infiltration Characteristics and Thickness**

Soil Name	Group*	Thickness(feet)
BkE	D	< 2
DnB	D	< 5
EeB	D	< 2
ErE	D	< 2
FaB	D	< 5
GsB	D	< 4

*\* Soil Group Definitions (Abbreviated)*

- A. *Soils having a high infiltration rate when thoroughly wetted.*
- B. *Soils having a moderate infiltration rate when thoroughly wetted.*
- C. *Soils having a slow infiltration rate when thoroughly wetted.*
- D. *Soils having a very slow infiltration rate when thoroughly wetted.*

6.  **Attachment B – Stratigraphic Column.** A stratigraphic column showing formations, members, and thicknesses is attached. The outcropping unit, if present, should be at the top of the stratigraphic column. Otherwise, the uppermost unit should be at the top of the stratigraphic column.
7.  **Attachment C – Site Geology.** A narrative description of the site specific geology including any features identified in the Geologic Assessment Table, a discussion of the potential for fluid movement to the Edwards Aquifer, stratigraphy, structure(s), and karst characteristics is attached.
8.  **Attachment D – Site Geologic Map(s).** The Site Geologic Map must be the same scale as the applicant's Site Plan. The minimum scale is 1": 400'  
 Applicant's Site Plan Scale: 1" = 200'  
 Site Geologic Map Scale: 1" = 200'  
 Site Soils Map Scale (if more than 1 soil type): 1" = 200'
9. Method of collecting positional data:
  - Global Positioning System (GPS) technology.
  - Other method(s). Please describe method of data collection: \_\_\_\_\_



- 10.  The project site and boundaries are clearly shown and labeled on the Site Geologic Map.
- 11.  Surface geologic units are shown and labeled on the Site Geologic Map.
- 12.  Geologic or manmade features were discovered on the project site during the field investigation. They are shown and labeled on the Site Geologic Map and are described in the attached Geologic Assessment Table.
  - Geologic or manmade features were not discovered on the project site during the field investigation.
- 13.  The Recharge Zone boundary is shown and labeled, if appropriate.
- 14. All known wells (test holes, water, oil, unplugged, capped and/or abandoned, etc.): If applicable, the information must agree with Item No. 20 of the WPAP Application Section.
  - There are 2 (#) wells present on the project site and the locations are shown and labeled. (Check all of the following that apply.)
    - The wells are not in use and have been properly abandoned.
    - The wells are not in use and will be properly abandoned.
    - The well is in use and comply with 16 TAC Chapter 76.
  - There are no wells or test holes of any kind known to exist on the project site.

### ***Section 2.01 Administrative Information***

- 15.  Submit one (1) original and one (1) copy of the application, plus additional copies as needed for each affected incorporated city, groundwater conservation district, and county in which the project will be located. The TCEQ will distribute the additional copies to these jurisdictions. The copies must be submitted to the appropriate regional office.

## **Attachment A**

### **Geologic Assessment Table (Form TCEQ-0585)**

GEOLOGIC ASSESSMENT TABLE			PROJECT NAME: RATTLESNAKE RANCH QUARRY																	
LOCATION			FEATURE CHARACTERISTICS										EVALUATION		PHYSICAL SETTING					
1A	1B*	1C*	2A	2B	3	4			5	5A	6	7	8A	8B	9	10		11		12
FEATURE ID	LATITUDE	LONGITUDE	FEATURE TYPE	POINTS	FORMATION	DIMENSIONS (FEET)			TREND (DEGREES)	PO WD	DENSITY (NO/FT)	APERTURE (FEET)	INFILL	RELATIVE INFILTRATION RATE	TOTAL	SENSITIVITY		CATCHMENT AREA (ACRES)		TOPOGRAPHY
						X	Y	Z		10					10	<40	≥40	<1.6	≥1.6	
S-1	30.746638	-97.758441	CD	5	Kkv	55	30	1	N/A				V	5	10	X		X		Hillside
S-2	30.786350	-97.759031	CD	5	Kkv	180	135	8	N/A				V, O	5	10	X		X		Hillside
S-3	30.785440	-97.759709	CD	5	Kkv	10	20	0.5	N/A				V, O	5	10	X		X		Hillside
S-4	30.785968	-97.759790	CD	5	Kkv	30	15	1	N/A				V, O	5	10	X		X		Floodplain/Drainage
S-5	30.788736	-97.759534	CD	5	Kkv	60	40	2	N/A				V, O	5	10	X		X		Hillside
S-6	30.790083	-97.757300	CD	5	Kkv	60	10	2	N/A				V, X	5	10	X		X		Hillside
S-7	30.788039	-97.757140	MB	30	Kc	0.33		Unknown	None				X	5	35	X		X		Hillside
S-8	30.788438	-97.756784	MB	30	Kc	10		25+	None				X	5	35	X		X		Hillside
S-9	30.789164	-97.754101	SC	20	Ked	0.75	0.5	3	10				O	5	25	X		X		Hillside
S-10	30.790141	-97.754061	SC	20	Ked	0.5	0.33	3	55				O	5	25	X		X		Hillside
S-11	30.786838	-97.762148	CD	20	Kkv	165	150	10	None				O	5	25	X		X		Hillside
S-12	30.788039	-97.757140	MB	30	Kc	0.33		Unknown	None				X	5	35	X		X		Hillside

\* DATUM: NAD 83

2A TYPE	TYPE	2B POINTS
C	Cave	30
SC	Solution cavity	20
SF	Solution-enlarged fracture(s)	20
F	Fault	20
O	Other natural bedrock features	5
MB	Manmade feature in bedrock	30
SW	Swallow hole	30
SH	Sinkhole	20
CD	Non-karst closed depression	5
Z	Zone, clustered or aligned features	30

8A INFILLING	
N	None, exposed bedrock
C	Coarse - cobbles, breakdown, sand, gravel
O	Loose or soft mud or soil, organics, leaves, sticks, dark colors
F	Fines, compacted clay-rich sediment, soil profile, gray or red colors
V	Vegetation. Give details in narrative description
FS	Flowstone, cements, cave deposits
X	Other materials

12 TOPOGRAPHY
Cliff, Hilltop, Hillside, Drainage, Floodplain, Streambed

I have read, I understood, and I have followed the Texas Commission on Environmental Quality's Instructions to Geologists. The information presented here complies with that document and is a true representation of the conditions observed in the field. My signature certifies that I am qualified as a geologist as defined by 30 TAC Chapter 213.

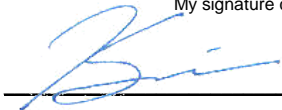

Date 12/15/2023

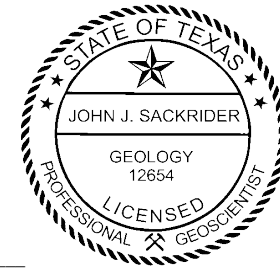

**Attachment B**  
**Stratigraphic Column**

### Generalized Stratigraphic Column

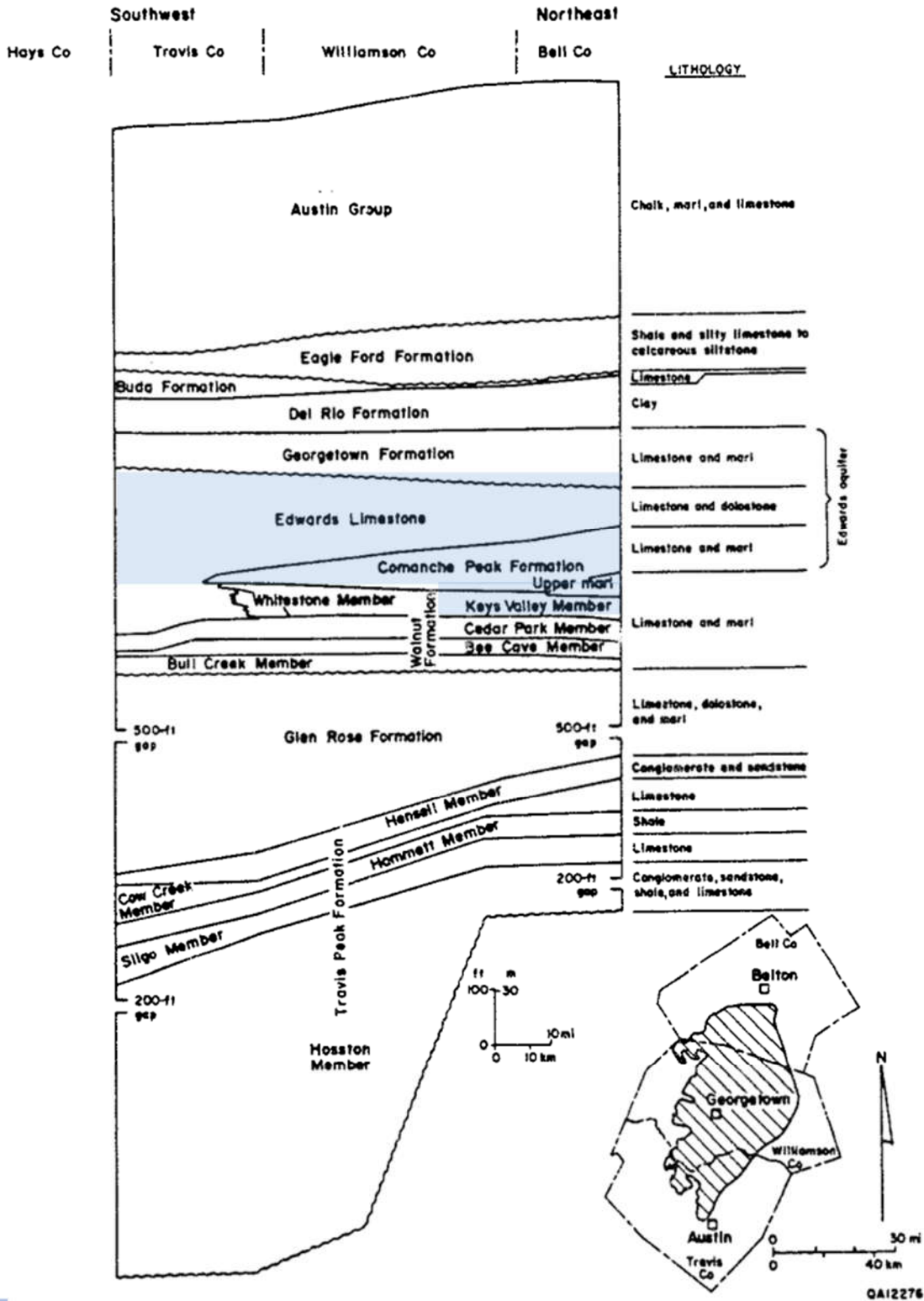

Indicates units observed at the surface of the Site.

Adapted from *Hydrology of the Northern Segment of the Edwards Aquifer, Austin region* (Senger, 1990).

## **Attachment C**

### **Site Geology (Geologic Narrative)**

## Geologic Narrative

### 1.0 PURPOSE

Westward Environmental, Inc. (WESTWARD) was retained by Ranger Excavating, LP, Inc. (Client) to prepare a Geologic Assessment (GA) on a ~163-acre tract (Site). This GA was prepared as a required attachment to a Water Pollution Abatement Plan (WPAP) for the Site as required by the Texas Commission of Environmental Quality (TCEQ).

### 2.0 REGULATORY GUIDANCE

#### Title 30, Chapter 213 of the Texas Administrative Code

This report was prepared in accordance with *Instructions for Geologists for Geologic Assessments on the Edwards Aquifer Recharge/Transition Zones (TCEQ-0585 (Rev. 10-01-04))* and will be reviewed pursuant to Title 30, Chapter 213 of the Texas Administrative Code.

### 3.0 PROJECT LOCATION

The Site is located between the cities of Florence and Georgetown, where Highway 195 intersects with Old 195 in Williamson County, Texas. The address is listed as 8880 Old 195, Florence, Texas 76527. The Site lies within the northern portion of the City of Georgetown's Extra-Territorial Jurisdiction (ETJ).

The western part of the Site is located over the Edwards Aquifer Contributing Zone (EACZ) and the eastern part of the Site is located over the Edwards Aquifer Recharge Zone (EARZ).

### 4.0 METHODOLOGY

As part of the GA, WESTWARD performed a desktop review of selected published information. WESTWARD also conducted a field investigation in accordance with *TCEQ-0585 (Rev. 10-01-04)*.

#### 4.1 Desktop Review

WESTWARD conducted a review of aerial imagery, the University of Texas Bureau of Economic Geology (BEG) Geologic Atlas of Texas (GAT) Austin Sheet, applicable U.S. Geological Survey (USGS) Topographic quadrangle(s) and geospatial dataset(s), the Texas Natural Resources Information System (TNRIS), the Texas Water Development Board's Water Data Interactive Groundwater Data Viewer (TWDB Viewer), the Railroad Commission of Texas (RRC), and the U.S. Department of Agriculture (USDA) National Resource Conservation Service (NRCS) Web Soil Survey prior to the field investigation.

#### 4.2 Field Investigation

A field investigation was performed at the Site by WESTWARD staff under the direction of John J. Sackrider, P.G. (TBPG Lic. No. 12654) on October 23 & 24, 2023. Field transects of the Site were walked in accordance with TCEQ-0585 (rev. 10-01-04).

## **5.0 DESKTOP REVIEW**

The desktop review was utilized for preliminary planning of the field investigation. The accuracy of the desktop review was limited by the accessibility, scale, and age of the data available.

### **5.1 Published Surface Geology**

A review of published geologic maps revealed three (3) geologic units mapped at the Site. They include the Cretaceous-aged Keys Valley Marl (Kkv), the Comanche Peak Limestone (Kc), and the Edwards Limestone (Ked).

### **5.2 Published Structure**

The Site is located within the Balcones Fault Zone (BFZ). The desktop review revealed that there are no faults going through the Site. However, there is one published fault that is mapped approximately 50 ft. outside of the western Site boundary trending southwest to northeast at approximately 18°. There is another fault trending southwest to northeast at approximately 46° less than a mile southeast of the Site. The fault that lies just outside of the boundary is the only fault visible within the mapped extents and is shown on the Site Geologic Map (Attachment D).

The average of these two neighboring faults was calculated to establish the dominant fault trend range at this Site, which for the purpose of this assessment, is approximated to be between 17° and 47°.

### **5.3 Karst Features**

The desktop review did not reveal karst features within the Site.

### **5.4 Non-karst & Manmade Features**

The desktop review of aerial imagery revealed two large ponds at the Site that are classified as non-karst closed depressions. A review of the TWDB Viewer did not reveal any onsite groundwater wells at the Site.

### **5.5 Soils**

Six (6) soil units were identified on the Site through the NRCS Web Soil Survey. They are detailed below as well as included on the Geologic Assessment Form TCEQ-0585 (Rev. 02-11-15). A Site Soils Map is included in Attachment D.



<b>Published Soil Unit Descriptions</b>			
<i>Soil Name</i>	<i>Group</i>	<i>Thickness (Feet)</i>	<i>Description</i>
Brackett gravelly clay (BkE), 3 to 12 percent slopes	D	< 2	6 to 20 inches to paralithic bedrock, well drained, moderately low to high (0.06 to 1.98 in/hr) Ksat capacity
Denton silty clay (DnB), 1 to 3 percent slopes	D	< 5	22 to 60 inches to lithic bedrock, well drained, moderately low to moderately high (0.06 to 0.20 in/hr) Ksat capacity
Eckrant stony clay (EeB), 0 to 3 percent slopes	D	< 2	4 to 20 inches to lithic bedrock, well drained, moderately low to moderately high (0.06 to 0.57 in/hr) Ksat capacity
Eckrant-Rock outcrop association (ErE), 1 to 10 percent slopes	D	< 2	4 to 20 inches to lithic bedrock, well drained, moderately low to moderately high (0.06 to 0.57 in/hr) Ksat capacity
Fairlie clay (FaB), 1 to 2 percent slopes	D	< 5	40 to 60 inches to paralithic bedrock, moderately well drained, very low to moderately low (0.00 to 0.06 in/hr) Ksat capacity
Georgetown stony clay loam (GsB), 1 to 3 percent slopes	D	< 4	24 to 40 inches to lithic bedrock, well drained, very low to moderately low (0.00 to 0.06 in/hr) Ksat capacity

## 6.0 FIELD INVESTIGATION

The field investigation was performed on October 24 & 25, 2023 by WESTWARD staff under the direction of John J. Sackrider, P.G. to verify the presence or absence of recharge features identified in the desktop review and to identify recharge features not found during the desktop review. Field reconnaissance was performed in accordance with the *TCEQ-0585-Instructions (Rev. 10-1-04)*.

### 6.1 Surface Geology

The mapped geologic units, Kkv, Kc, Ked, were all observed at the Site in places where bedrock was exposed and by the presence of scattered rock at the surface. Observations at the Site indicate that the actual formation contacts varied slightly from the contacts shown on the published maps. Contact lines were redrawn based on outcrop points where a geologic unit was observed and followed using topography lines. An updated Site Geology Map based on the field observations made during this field investigation is included in Appendix D.

### 6.2 Structure

Evidence of faults was not observed during the field investigation.

### 6.3 Karst Features

Two (2) solution cavities were identified and recorded during the field investigation. Neither of these features are rated sensitive.

### 6.4 Non-karst & Manmade Features

Seven (7) non-karst closed depressions and three (3) manmade features in bedrock were identified and recorded during the field investigation. Two (2) of the three (3) manmade features in bedrock are wells. None of these features are rated sensitive.

### 6.5 Feature Descriptions

#### S-1 (CD)

**Not Sensitive**

Feature S-1 is a non-karst closed depression located along the entry road on the southwestern part of the Site. The feature measures approximately 55 ft. x 30 ft. x 1 ft. and the floor was heavily vegetated at the time of the field investigation. The catchment area of the feature is less than 1.6 acres, and the interpreted probability of rapid infiltration is low. This feature is rated not sensitive.

#### S-2 (CD)

**Not Sensitive**

Feature S-2 is a large non-karst closed depression on the southwestern part of the Site. The feature measures approximately 180 ft. x 135 ft. x 8 ft. and the floor consists of vegetated dark soil. Mud cracks were observed at the time of the field investigation. The catchment area of the feature is greater than 1.6 acres but due to the vegetated fine-grained soil floor, the interpreted probability of rapid infiltration is low. This feature is rated not sensitive.

#### S-3 (CD)

**Not Sensitive**

Feature S-3 is a non-karst closed depression near the southern Site boundary. The feature measures approximately 10 ft. x 20 ft. x 0.5 ft. and the floor consists of vegetated dark soil. The catchment area is less than 1.6 acres, and the interpreted probability of rapid infiltration is low. This feature is rated not sensitive.

#### S-4 (CD)

**Not Sensitive**

Feature S-4 is a non-karst closed depression located along the road and within the floodplain on the southwestern part of the Site. The feature measures approximately 30 ft. x 15 ft. x 1 ft. and the floor consist of vegetated dark soil. The catchment area is greater than 1.6 acres, but due to the vegetated fine-grained soil floor, the interpreted probability of rapid infiltration is low. This feature is rated not sensitive.

#### S-5 (CD)

**Not Sensitive**

Feature S-5 is a non-karst closed depression located in the terraced area on the western part of the Site. The feature measures approximately 60 ft. x 40 ft. x 2 ft. and is floored with dark soil and short growth vegetation. The catchment area is less than 1.6 acres, and the interpreted probability of rapid infiltration is low. This feature is rated not sensitive.

#### S-6 (CD)

**Not Sensitive**

Feature S-6 is a non-karst closed depression located on the northcentral part of the Site near the tree line separating the densely vegetated portion from the open field. The feature

measures approximately 60 ft. x 10 ft. x 2 ft. and is floored with vegetation and covered with tall trees. The feature was filled with trash at the time of the field investigation. The catchment area is less than 1.6 acres and the interpreted probability of rapid infiltration is low. This feature is rated not sensitive.

**S-7 (MB-W)**

**Not Sensitive**

Feature S-7 is a water well classified as a manmade feature in bedrock located near the main house in the central part of the Site. The well is inside a well house floored with a concrete slab. The casing is a minimum of 0.33 ft. in diameter and is suspected to be made of steel. This could not be confirmed at the time of the field investigation as it is covered by a steel plate that is flush with the concrete slab. The depth is unknown as there was no public information available pertaining to this well during the desktop review. The catchment area is less than 1.6 acres, and the interpreted probability of rapid infiltration is low. This feature is rated not sensitive.

**S-8 (MB)**

**Not Sensitive**

Feature S-8 is a cistern which is classified as a manmade feature in bedrock located next to the main house in the central part of the Site. The feature measures approximately 10 ft. wide in diameter with an unknown depth estimated to be at least 25 ft. It was holding water at the time of the field investigation. The feature is lined with concrete on the inside and the opening extends approximately 1.5 ft. above the ground surface with mortared stone sides and a wooden cap which serves as a cover for the opening of the feature. The catchment area is less than 1.6 acres, and the interpreted probability of rapid infiltration is low. This feature is rated not sensitive.

**S-9 (SC)**

**Not Sensitive**

Feature S-9 appears to be a solution cavity located on the southcentral part of the Site. It is possible that the bedrock observed consists of float rock, but the feature is included here to be conservative. The feature measures approximately 0.75 ft. x 0.5 ft. x 3 ft. and has an approximate trend of 10°. It was infilled with dark soil at the time of the field investigation. The catchment area is less than 1.6 acres, and the interpreted probability of rapid infiltration is low. This feature is rated not sensitive.

**S-10 (SC)**

**Not Sensitive**

Feature S-10 is a solution cavity located on the heavily vegetated central part of the Site. The feature measures approximately 0.5 ft. x 0.33 ft. x 3 ft. and has an approximate trend of 55°. It was infilled with dark soil and organic debris at the time of the field investigation. The catchment area for this feature is less than 1.6 acres and the interpreted probability of rapid infiltration is low. This feature is rated not sensitive.

**S-11 (CD)**

**Not Sensitive**

Feature S-11 is a large non-karst closed depression located on the western part of the Site near Rattlesnake Rd. The feature measures approximately 165 ft. x 150 ft. x 10 ft. The floor consists of dark soil which was moist at the time of the field investigation and appeared to have been holding water recently so although the catchment area for this feature is greater than 1.6 acres, the interpreted probability of rapid infiltration is low. The feature is rated not sensitive.

**S-12 (MB-W)**

**Not Sensitive**

Feature S-12 is a water well classified as a manmade feature in bedrock. It is located next to S-7 inside the well house. The casing is estimated to measure approximately 0.33 ft. in diameter and is made of steel. The depth is unknown as there was no public information available pertaining to this well during the desktop review. This well appeared to not be in use as the pipe extending from it was not connected to anything. It is likely that S-7 is a replacement well for S-12. The catchment area is less than 1.6 acres, and the interpreted probability of rapid infiltration is low. This feature is rated not sensitive.

### SELECT PHOTOGRAPHS

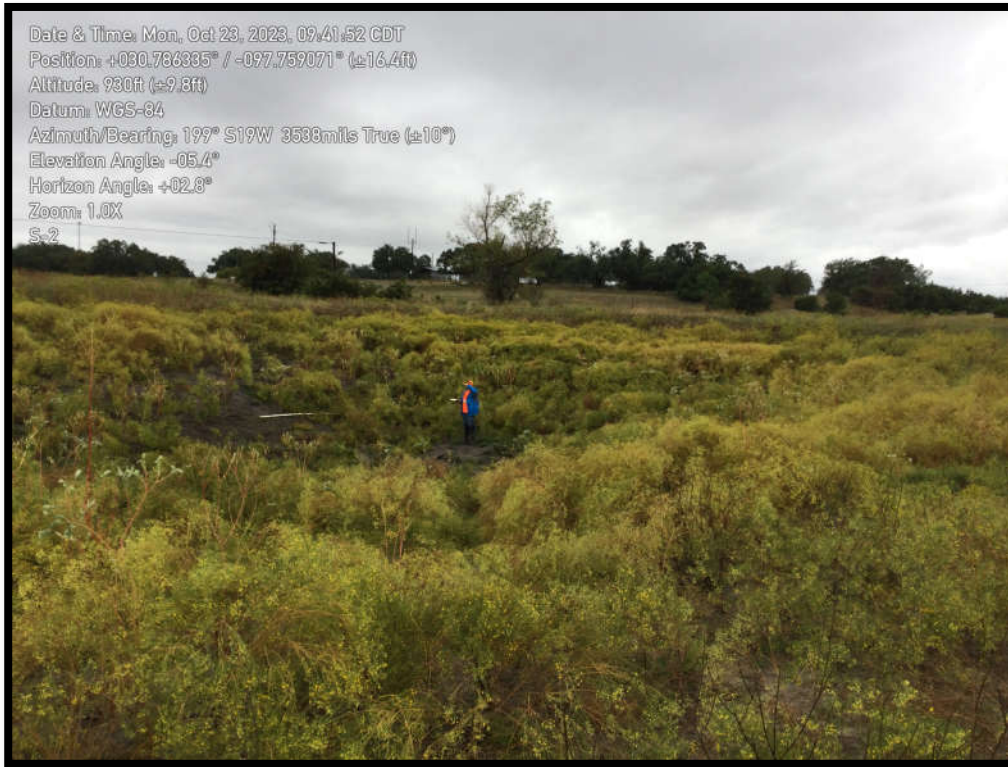

S-2: Closed depression on the southwestern part of the Site.



S-5: Closed depression in the terraced field on the western part of the Site.



S-6: Closed depression filled with trash on the northcentral part of the Site.



Well house containing features S-7 and S-12.



Groundwater wells S-7 (left) and S-12 (right).



S

S-8: Cistern located by the main house on the central part of the Site.



S-8: Note the water line inside the cistern.



S-9: Solution cavity located on the southcentral part of the Site.





S-10: Solution cavity located on the heavily vegetated central part of the Site.



S-11: Closed depression located on the western part of the Site by Rattlesnake Rd.

## **Attachment D**

### **Site Geologic Map Site Soils Map**

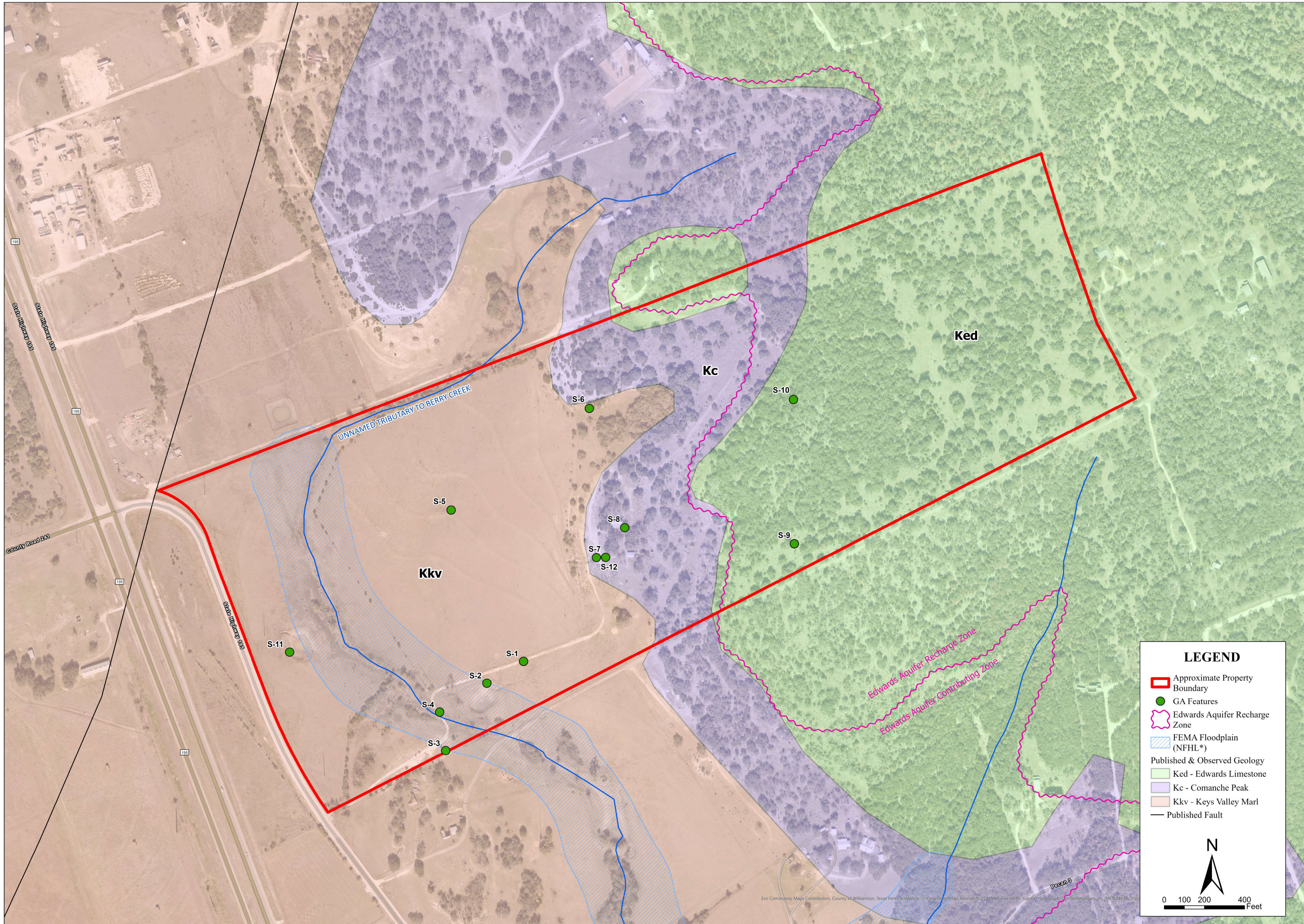
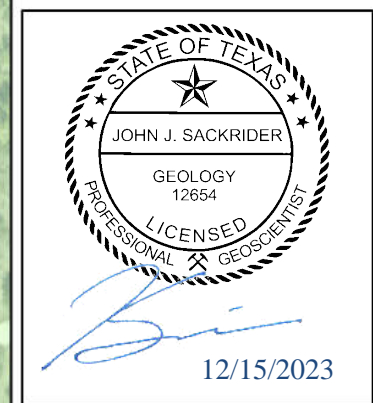

IMAGE: ESRI WORLD IMAGERY  
 ISSUE DATE: 12/7/2023  
 DRAWN BY: CPT  
 CHECKED BY: JJS  
 SCALE: 1" = 200'  
 JOB NO.: 11260-005

SHEET NO.:  
**01**  
 OF 02

**WESTWARD**  
 Environmental Engineering, Natural Resources,  
 P.O. Box 2205, Boerne, Texas 78006  
 (830) 249-8284 Fax: (830) 249-0221  
 TBPE REG. NO.: F-4524  
 TBPG REG. NO.: 50112

REV	DESCRIPTION	BY	DATE



**LEGEND**

- Approximate Property Boundary
- GA Features
- Edwards Aquifer Recharge Zone
- FEMA Floodplain (NFHL\*)
- Published & Observed Geology
- Ked - Edwards Limestone
- Kc - Comanche Peak
- Kkv - Keys Valley Marl
- Published Fault

**SITE GEOLOGIC MAP**  
 RATTLESNAKE RANCH QUARRY  
 RANGER EXCAVATING, LP  
 FLORENCE, WILLIAMSON COUNTY, TX 76527

REV	DESCRIPTION	BY	DATE

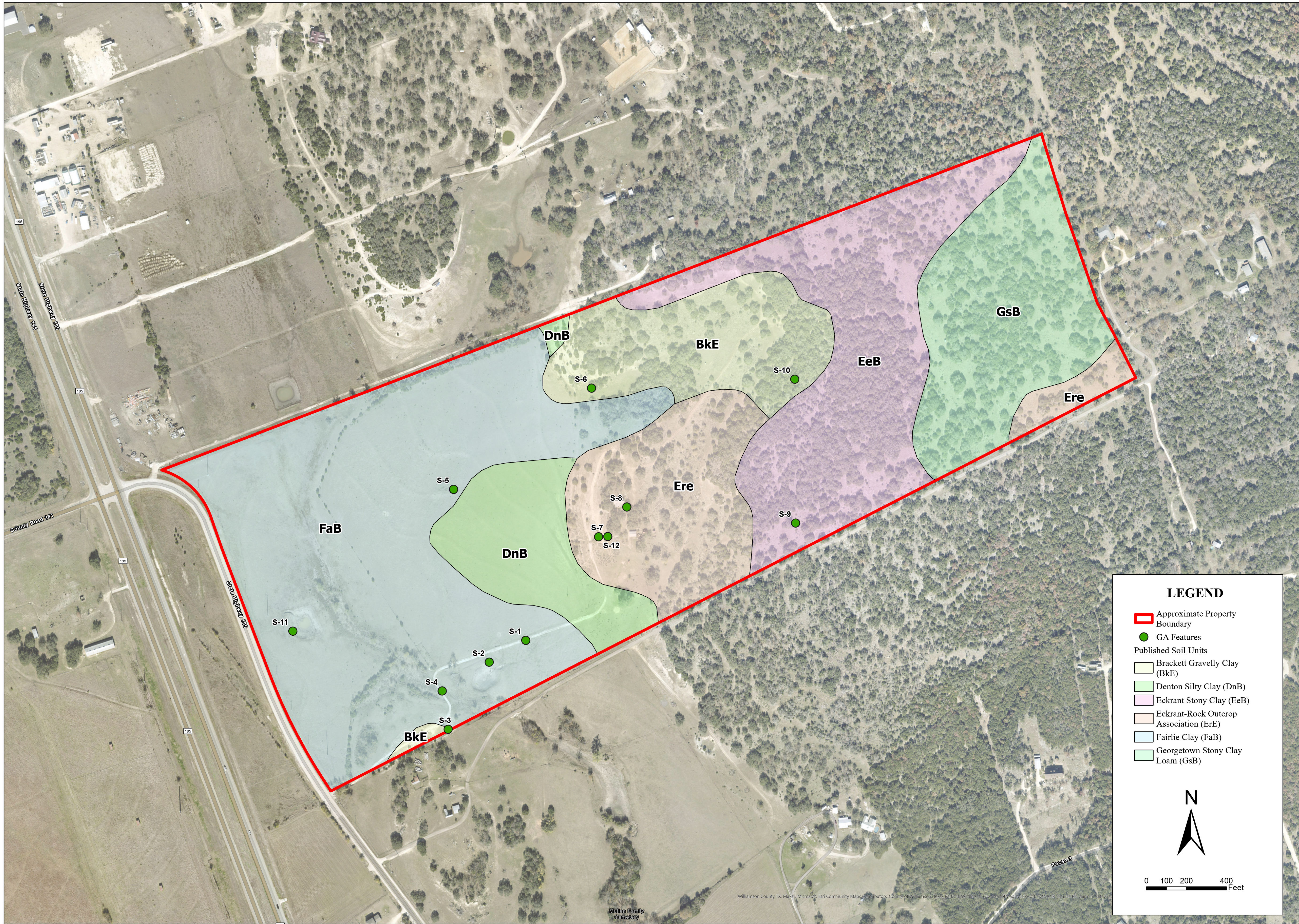
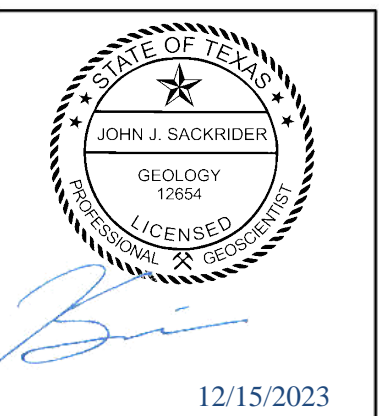

**LEGEND**

- Approximate Property Boundary
- GA Features
- Published Soil Units
- Brackett Gravelly Clay (BkE)
- Denton Silty Clay (DnB)
- Eckrant Stony Clay (EeB)
- Eckrant-Rock Outcrop Association (ErE)
- Fairlie Clay (FaB)
- Georgetown Stony Clay Loam (GsB)

**SITE SOILS MAP**  
 RATTLESNAKE RANCH QUARRY  
 RANGER EXCAVATING, LP  
 FLORENCE, WILLIAMSON COUNTY, TX 78132

Williamson County TX, Maxar, MicroSoft, Esri Community Maps, Esri, Autodesk, Civil 3D, Williams County, Texas, Barossa, W. Williams County, Texas, MicroSoft, 2019, Esri, Inc. All rights reserved.

Mullen Family Cemetery

# Aboveground Storage Tank Facility Plan Application

## Texas Commission on Environmental Quality

For Permanent Storage on The Edwards Aquifer Recharge and Transition Zones And Relating to 30 TAC §213.5(e), Effective June 1, 1999

*To ensure that the application is administratively complete, confirm that all fields in the form are complete, verify that all requested information is provided, consistently reference the same site and contact person in all forms in the application, and ensure forms are signed by the appropriate party.*

*Note: Including all the information requested in the form and attachments contributes to more streamlined technical reviews.*

## Signature

To the best of my knowledge, the responses to this form accurately reflect all information requested concerning the proposed regulated activities and methods to protect the Edwards Aquifer. This **Aboveground Storage Tank Facility Plan Application** is hereby submitted for TCEQ review and Executive Director approval. The application was prepared by:

Print Name of Customer/Agent: Andrea Kidd, P.E.

Texas License No. 132541 | Firm No. 4524

Date: 2/22/2024

Signature of Engineer/Agent :

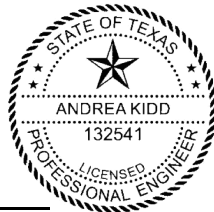

Regulated Entity Name: Rattlesnake Ranch Quarry

## Aboveground Storage Tank (AST) Facility Information

1. Tanks and substance stored:

**Table 1 - Tank and Substance Storage**

AST Number	Size (Gallons)	Substance to be Stored	Tank Material
1	10,000	Diesel	Double Walled-Steel
2	10,000	Diesel	Double Walled-Steel
3	1,000	Used oil	Double Walled-Steel
4	515	Transmission Fluid	Double-Walled Steel
5	515	Maintenance Oil	Double Walled-Steel

<i>AST Number</i>	<i>Size (Gallons)</i>	<i>Substance to be Stored</i>	<i>Tank Material</i>
6	515	Maintenance Oil	Double Walled-Steel

**Total x 1.5 = 33,817.5 Gallons**

2.  The AST will be placed within a containment structure that is sized to capture one and one-half (1 1/2) times the storage capacity of the system. For facilities with more than one tank system, the containment structure is sized to capture one and one-half (1 1/2) times the cumulative storage capacity of all systems.
- Attachment A - Alternative Methods of Secondary Containment.** Alternative methods for providing secondary containment are proposed. Specifications that show equivalent protection for the Edwards Aquifer are attached. **Discussion provided for piping and dispensers.**

3. Inside dimensions and capacity of containment structure(s):

**Table 2 - Secondary Containment – N/A**

<i>Length (L) (Ft.)</i>	<i>Width (W) (Ft.)</i>	<i>Height (H) (Ft.)</i>	<i>L x W x H = (Ft3)</i>	<i>Gallons</i>

**Total: \_\_\_\_\_ Gallons**

4.  All piping, hoses, and dispensers will be located inside the containment structure.
- Some of the piping to dispensers or equipment will extend outside the containment structure.
- The piping will be aboveground
- The piping will be underground
5.  The containment area must be constructed of and in a material impervious to the substance(s) being stored. The proposed containment structure will be constructed of the tanks are double-walled steel, piping will be double-walled, and metal drip pans will provide containment for spills and drips.
6.  **Attachment B - Scaled Drawing(s) of Containment Structure.** A scaled drawing of the containment structure that shows the following is attached: **N/A – no containment structure**
- Interior dimensions (length, width, depth and wall and floor thickness).
- Internal drainage to a point convenient for the collection of any spillage.
- Tanks clearly labeled.
- Piping clearly labeled.
- Dispenser clearly labeled.

## **Site Plan Requirements**

**Items 7 - 18 must be included on the Site Plan.**

7.  The Site Plan must have a minimum scale of 1" = 400'.  
Site Plan Scale: 1" = 200'.
8. 100-year floodplain boundaries:
- Some part(s) of the project site is located within the 100-year floodplain. The floodplain is shown and labeled.
  - No part of the project site is located within the 100-year floodplain.
  - The 100-year floodplain boundaries are based on the following specific (including date of material) sources(s): FEMA Panel No. 48491C0100E eff 9/26/2008 & 48491C0125F eff 12/20/2019.
9.  The layout of the development is shown with existing and finished contours at appropriate, but not greater than ten-foot contour intervals. Show lots, recreation centers, buildings, roads, etc.
- The layout of the development is shown with existing contours. Finished topographic contours will not differ from the existing topographic configuration and are not shown.
10. All known wells (oil, water, unplugged, capped and/or abandoned, test holes, etc.):
- There are two (2) wells present on the project site and the locations are shown and labeled. (Check all of the following that apply):
    - The wells are not in use and have been properly abandoned.
    - One well not in use and will be properly abandoned.
    - One well in use and complies with 16 TAC § 76.
  - There are no wells or test holes of any kind known to exist on the project site.
11. Geologic or manmade features which are on the site:
- All sensitive geologic or manmade features identified in the Geologic Assessment are shown and labeled.
  - No sensitive geologic or manmade features were identified in the Geologic Assessment.
  - Attachment C - Exception to the Geologic Assessment.** A request and justification for an exception to a portion of the Geologic Assessment is attached.
12.  The drainage patterns and approximate slopes anticipated after major grading activities.
13.  Areas of soil disturbance and areas which will not be disturbed.
14.  Locations of major structural and nonstructural controls. These are the temporary and permanent best management practices.
15.  Locations where soil stabilization practices are expected to occur.

16.  Surface waters (including wetlands).  
 N/A
17.  Locations where stormwater discharges to surface water or sensitive features.  
 There will be no discharges to surface water or sensitive features.
18.  Legal boundaries of the site are shown.

### **Best Management Practices**

19.  Any spills must be directed to a point convenient for collection and recovery. Spills from storage tank facilities must be removed from the controlled drainage area for disposal within 24 hours of the spill.  
 In the event of a spill, any spillage will be removed from the containment structure within 24 hours of the spill and disposed of properly. **N/A - no containment structures onsite.**  
 In the event of a spill, any spillage will be drained from the containment structure through a drain and valve within 24 hours of the spill and disposed of properly. The drain and valve system are shown in detail on the scaled drawing.
20.  All stormwater accumulating inside the containment structure will be disposed of through an authorized waste disposal contractor. **N/A – no containment structures onsite.**  
 Containment area will be covered by a roof.  
 Containment area will not be covered by a roof.  
 A description of the alternate method of stormwater disposal is submitted for the executive director's review and approval and is attached.
21.  **Attachment D - Spill and Overfill Control.** A site-specific description of the methods to be used at the facility for spill and overfill control is attached.
22.  **Attachment E - Response Actions to Spills.** A site-specific description of the planned response actions to spills that will take place at the facility is attached.

### **Administrative Information**

23. A Water Pollution Abatement Plan (WPAP) is required for construction of any associated commercial, industrial or residential project located on the Recharge Zone.  
 The WPAP application for this project was approved by letter dated \_\_\_\_\_. A copy of the approval letter is attached at the end of this application.  
 The WPAP application for this project was submitted to the TCEQ on December 19, 2023, but has not been approved. **EAPP ID 11003852**



- A WPAP application is required for an associated project, but it has not been submitted.
  - There will be no building or structure associated with this project. In the event a building or structure is needed in the future, the required WPAP will be submitted to the TCEQ.
  - The proposed AST is located on the Transition Zone and a WPAP is not required. Information requested in 30 TAC 213.5 subsection (b) (4)(B) and (C) and (5) is provided with this application. (Forms TCEQ-0600 Permanent Stormwater Section and TCEQ-0602 Temporary Stormwater Section or Stormwater Pollution Prevention Plan/SW3P).
24.  This facility is subject to the requirements for the reporting and cleanup of surface spills and overfills pursuant to 30 TAC 334 Subchapter D relating to Release Reporting and Corrective Action.
25.  Submit one (1) original and one (1) copy of the application, plus additional copies as needed for each affected incorporated city, groundwater conservation district, and county in which the project will be located. The TCEQ will distribute the additional copies to these jurisdictions. The copies must be submitted to the appropriate regional office.
26.  Any modification of this AST Facility Plan application will require executive director approval, prior to construction, and may require submission of a revised application, with appropriate fees.

**Ranger Excavating, LP  
Rattlesnake Ranch Quarry**

**AST Plan Application (TCEQ-0575)  
Attachment A**

**Alternative Methods of Secondary Containment**

All the proposed tanks in this application are double-walled steel tanks. Double-walled tanks are manufactured to provide secondary containment for their contents. The interstitial space between the steel walls serves as secondary containment. Discharges from the inner tank will flow into the outer wall that encloses it. All tanks will be fabricated per UL-142 specifications. Manufacturer drawings of the tanks have been included in this application. Double-walled piping has been specified for all tanks.

The diesel tanks (AST #1 and #2) will sit on compacted base and will have double-walled fill lines and double-walled dispensing lines plumbed to the top of each tank to prevent free outward flow of the tank contents. Metal drip pans will be constructed to provide containment for potential drips at the nozzles during refueling.

ASTs #3, 4, 5, and 6 will be located inside the future maintenance shop. The used oil tank (AST #3) will have no piping associated with it. ASTs #4, 5, and 6 will have double-walled piping and metal drip pans will be constructed to provide containment for potential drips at the dispensing areas for the maintenance fluids.

The site will be subject to the Environmental Protection Agency's requirements as specified in 40 CFR Part 112 regarding Spills, Prevention, Control, and Countermeasures (SPCC). The site will maintain an SPCC Plan in accordance with applicable rules.

**AST Plan Application (TCEQ-0575)  
Attachment B**

**Scaled Drawing of Containment Structure**

This section is not applicable as there are no proposed constructed containment structures.

**AST Plan Application (TCEQ-0575)  
Attachment D**

**Spill and Overfill Control**

Personnel in charge of loading/unloading tanks will be trained to utilize proper techniques and preventive measures to avoid spills. The tank levels will be checked prior to loading/unloading and the operator will be present at all times during tank loading/unloading. The tanks will be monitored as they are filled, either visually or in another manner, dependent upon the indicator present in the tank. ASTs #1 and #2 will be equipped with an interstitial monitor and overfill alarm.

**Ranger Excavating, LP  
Rattlesnake Ranch Quarry**

**AST Plan Application (TCEQ-0575)  
Attachment E**

**Spill Response Actions**

**Education**

- (1) Be aware that different materials pollute in different amounts. Make sure that each employee knows what a “significant spill” is for each material they use, and what is the appropriate response for “significant” and “insignificant” spills. Employees should also be aware of when spill must be reported to the TCEQ.
- (2) Educate employees and subcontractors on potential dangers to humans and the environment from spills and leaks.
- (3) Hold regular meetings to discuss and reinforce appropriate disposal procedures (incorporate into regular safety meetings).
- (4) Establish a continuing education program to indoctrinate new employees.
- (5) Have contractor’s superintendent or representative oversee and enforce proper spill prevention and control measures.

**General Measures**

- (1) To the extent that the work can be accomplished safely, spills of oil, petroleum products, substances listed under 40 CFR parts 110,117, and 302, and sanitary and septic wastes should be contained and cleaned up immediately.
- (2) Store hazardous materials and wastes in covered containers and protect from vandalism.
- (3) Place a stockpile of spill cleanup materials where it will be readily accessible.
- (4) Train employees in spill prevention and cleanup.
- (5) Designate responsible individuals to oversee and enforce control measures.
- (6) Spills should be covered and protected from stormwater run on during rainfall to the extent that it doesn’t compromise clean up activities.
- (7) Do not bury or wash spills with water.
- (8) Store and dispose of used clean up materials, contaminated materials, and recovered spill material that is no longer suitable for the intended purpose in conformance with the provisions in applicable BMPs.

## **Ranger Excavating, LP Rattlesnake Ranch Quarry**

(9) Do not allow water used for cleaning and decontamination to enter storm drains or watercourses. Collect and dispose of contaminated water in accordance with applicable regulations.

(10) Contain water overflow or minor water spillage and do not allow it to discharge into drainage facilities or watercourses.

(11) Place Safety Data Sheets (SDS), as well as proper storage, cleanup, and spill reporting instructions for hazardous materials stored or used on the project site in an open, conspicuous, and accessible location.

(12) Keep waste storage areas clean, well-organized, and equipped with ample cleanup supplies as appropriate for the materials being stored. Perimeter controls, containment structures, covers, and liners should be repaired or replaced as needed to maintain proper function.

### **Cleanup**

(1) Clean up leaks and spills immediately.

(2) Any spills from an AST facility must be removed from the controlled drainage area for disposal within 24 hours of the spill.

(3) Use a rag for small spills on paved surfaces, a damp mop for general cleanup, and absorbent material for larger spills. If the spilled material is hazardous, then the used cleanup materials are also hazardous and must be disposed of as hazardous waste.

(4) Never hose down or bury dry material spills. Clean up as much of the material as possible and dispose of properly. See the waste management BMPs in this section for specific information.

### **Minor Spills**

(1) Minor spills typically involve small quantities of oil, gasoline, paint, etc. which can be controlled by the first responder at the discovery of the spill.

(2) Use absorbent materials on small spills rather than hosing down or burying the spill.

(3) Absorbent materials should be promptly removed and disposed of properly.

(4) Follow the practice below for a minor spill:

(5) Contain the spread of the spill.

(6) Recover spilled materials.

**Ranger Excavating, LP**  
**Rattlesnake Ranch Quarry**

(7) Clean the contaminated area and properly dispose of contaminated materials.

**Semi-Significant Spills**

Semi-significant spills still can be controlled by the first responder along with the aid of other personnel such as laborers and the foreman, etc. This response may require the cessation of all other activities.

Spills should be cleaned up immediately:

- (1) Contain spread of the spill.
- (2) Notify the project foreman as soon as possible.
- (3) If the spill occurs on paved or impermeable surfaces, clean up using "dry" methods (absorbent materials, cat litter and/or rags). Contain the spill by encircling with absorbent materials and do not let the spill spread widely.
- (4) If the spill occurs in dirt areas, as soon as possible contain the spill by constructing an earthen dike. Dig up and properly dispose of contaminated soil.
- (5) If the spill occurs during rain, cover spill with tarps or other material to prevent contaminating runoff.

**Significant/Hazardous Spills**

For significant or hazardous spills that are in reportable quantities:

- (1) Notify the TCEQ by telephone as soon as possible and within 24 hours at 512-339-2929 (Austin) or 210-490-3096 (San Antonio) between 8 AM and 5 PM. After hours, contact the Environmental Release Hotline at 1-800-832-8224. It is the contractor's responsibility to have all emergency phone numbers at the construction site.
- (2) For spills of federal reportable quantities, in conformance with the requirements in 40 CFR parts 110, 119, and 302, the contractor should notify the National Response Center at (800) 424-8802.
- (3) Notification should first be made by telephone and followed up with a written report.
- (4) The services of a spills contractor or a Haz-Mat team should be obtained as soon as possible. Construction personnel should not attempt to clean up until the appropriate and qualified staffs have arrived at the job site.
- (5) Other agencies which may need to be consulted include, but are not limited to, the City Police Department, County Sheriff Office, Fire Departments, etc.

**Ranger Excavating, LP  
Rattlesnake Ranch Quarry**

In the event of a reportable spill, the following Emergency Response Agencies can be contacted for assistance. Always inform your supervisor of a reportable spill as soon as possible. Follow company policy when responding to an emergency.

State Emergency Response Commission	(512) 463-7727
National Response Center	(800) 424-8802
US EPA Region 6, Dallas, 24-hr Number	(866) 372-7745
National Weather Service	(281) 337-5074
TCEQ 24-hr	(800) 832-8224
TCEQ Region 11 Austin Office	(512) 339-2929

**Vehicle and Equipment Fueling**

- (1) If fueling must occur on site, use designated areas, located away from drainage courses, to prevent the run-on of stormwater and the runoff of spills.
- (2) Discourage “topping off” of fuel tanks.
- (3) Always use secondary containment, such as a drip pan, when fueling to catch spills/ leaks.
- (4) Drip pans will be used to control spills from fueling.



General Notes:

Tank Type: Double Wall  
 Construction Code: U/L 142 Approved  
 Estimated Weight: = 18,500 lbs  
 Material Type: Mild Carbon Steel A1011 or A-36 Type  
 Tank Thickness: Inside 1/4", Outside 3/16 Gauge  
 Structural Supports: I-Beams  
 Design and Operating Temperature: Ambient Conditions  
 Design and Operating Pressure: Atmospheric or 1.0 psi  
 Radiography: N/A  
 Corrosion Allowance: N/A  
 Tested: 3-5 psi, soap and water  
 Fitting Type: NPT Threadlet or Coupling (National Pipe Thread)  
 Internal Seal-Weld: N/A  
 Internal Coating: N/A (Bare Metal)  
 External Coating: Gray Enamel

Additional Note: 1) All fittings may be spaced accordingly  
 2) Stationary use only. Move/lift tanks while empty  
 3) All primary tank openings located on top  
 4) Outside tank is a tight wrap

Schedule Of Fittings		
Ref	Qty	Description
A	3	4" NPT
A1	1	4" NPT + Fill Cap
B	1	Normal Vent
B1	1	2" Outer Shell Monitor
C	2	Lifting Lug
D	1	8" NPT + Inside EV
D1	1	8" NPT + Outside EV
E	1	18" Manhole
F	Varies	Braces
G	Varies	Angle Skid Pads

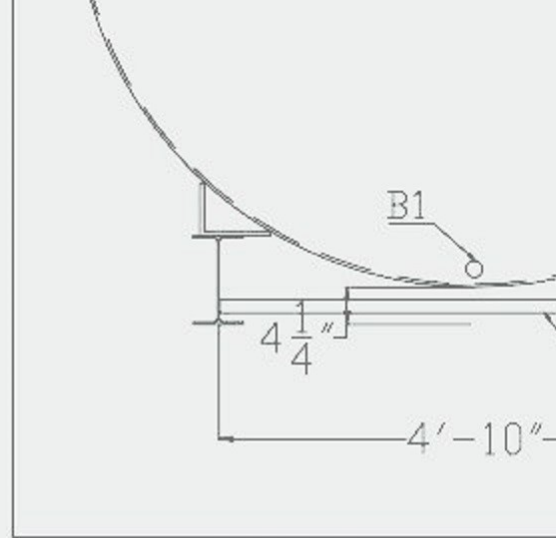

Elevation View

Scale: 1/2" = 1'-0"

Front View

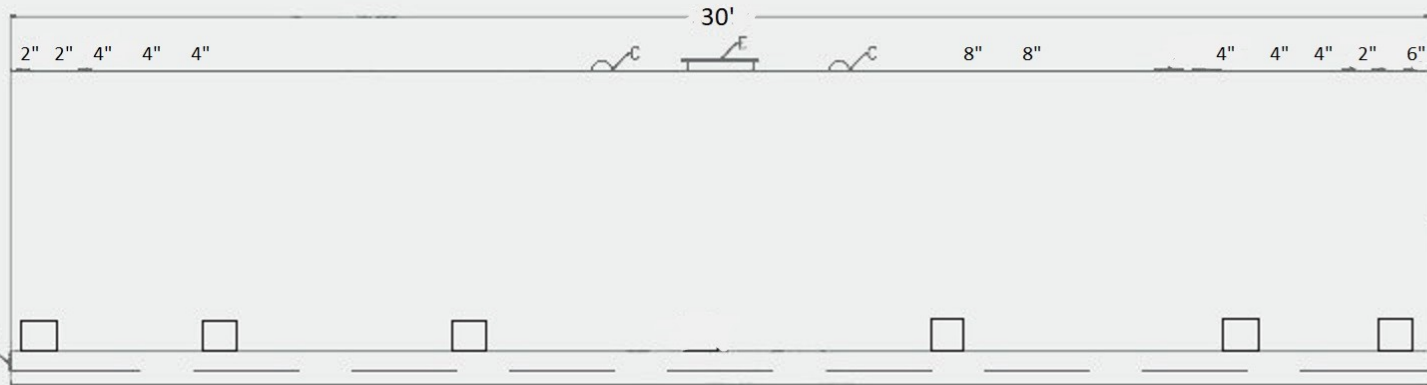
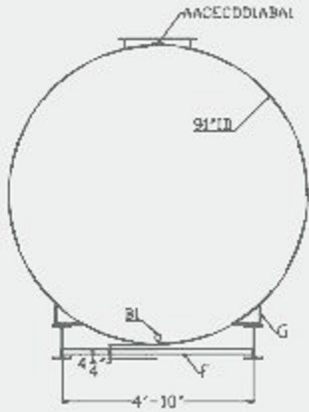

10,000 GI

Petroleum Materials, LLC		
Date: 7/30/2020	Size	Standard
Scale: 3/16" = 1'-0"	DRW #:	DW-UL142
Rev: 0	File Name:	10,000 DW-UL142
Designed By: J. Pavlock	Ref:	N/A



Front View

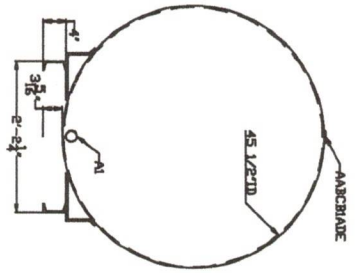

Elevation View

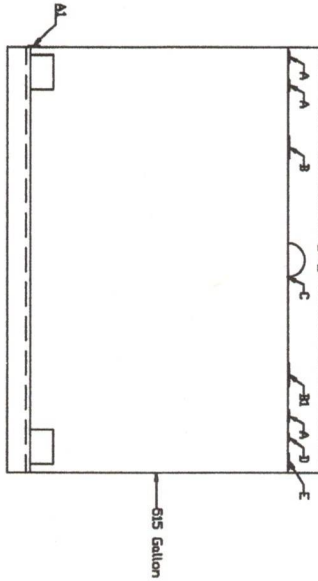
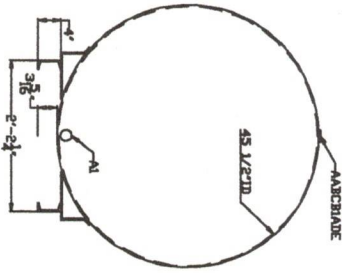
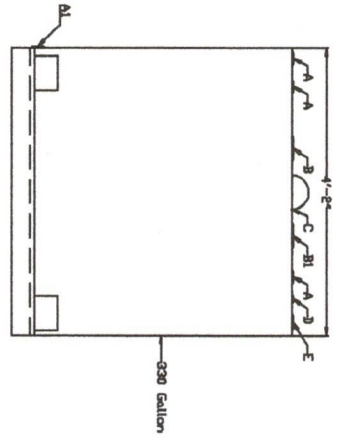

AST 4, 5, 6

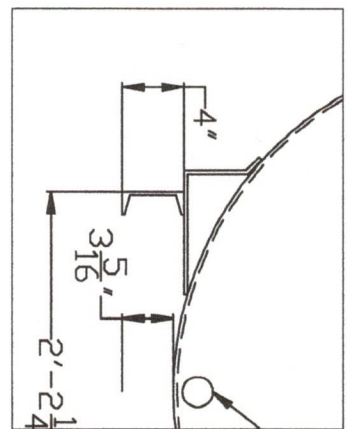

Scale 1" = 1'-0"

Schedule Df Fittings	
Raft Qty	Description
A 3	2" NPT
A1 1	2" NPT Outer Shell Monitor
B 1	4" NPT + Inside EV
B1 1	4" NPT + Outside EV
B2 1	6" NPT + Inside EV
B3 1	6" NPT + Outside EV
C 1 or 2	Lifting Lug
D 1	1 1/4" NPT + T-Vent
D1 1	2" NPT + T-Vent
E 1	2 1/2" NPT + Fill Cap

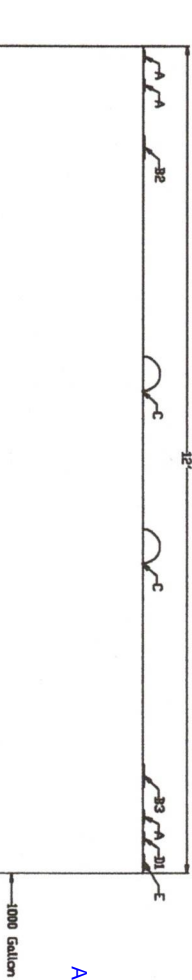

AST 3

**General Notes:**  
 Tank Type: Double Wall  
 Construction Code: U/L 142  
 Estimated Weight: 330 Gallon = 800 lbs  
 515 Gallon = 1000 lbs  
 Material Type: Mild Steel  
 Tank Thickness: 1000 Gallon = Inside 10 Gauge  
 330/515 Gallon = All 12 Gauge  
 Corrosion Allowance: N/A  
 Structural Supports: Angle Iron + Channel Iron  
 Design and Operating Pressure: Ambient Conditions  
 Radiography: N/A  
 Fitting Type: NPT, Flanges: Optional  
 Internal Coating: N/A  
 External Coating: Red Oxide Primer

**Additional Notes:**  
 1) Stationary use only. Move/lift tanks while empty.  
 2) All primary tank openings located on top.  
 3) All top fittings may be spaced accordingly.  
 4) Outside tank is a tight wrap.

# Temporary Stormwater Section

## Texas Commission on Environmental Quality

for Regulated Activities on the Edwards Aquifer Recharge Zone and Relating to 30 TAC §213.5(b)(4)(A), (B), (D)(I) and (G); Effective June 1, 1999

**To ensure that the application is administratively complete, confirm that all fields in the form are complete, verify that all requested information is provided, consistently reference the same site and contact person in all forms in the application, and ensure forms are signed by the appropriate party.**

**Note: Including all the information requested in the form and attachments contributes to more streamlined technical reviews.**

## Signature

To the best of my knowledge, the responses to this form accurately reflect all information requested concerning the proposed regulated activities and methods to protect the Edwards Aquifer. This **Temporary Stormwater Section** is hereby submitted for TCEQ review and executive director approval. The application was prepared by:

Print Name of Engineer/Agent: Andrea Kidd, P.E.

TX License No. 132541 | TX Firm No. 4524

Date: 3/12/2024

Signature of Engineer/Agent:



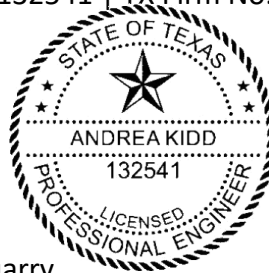

Regulated Entity Name: Rattlesnake Ranch Quarry

## Project Information

### Potential Sources of Contamination

*Examples: Fuel storage and use, chemical storage and use, use of asphaltic products, construction vehicles tracking onto public roads, and existing solid waste.*

1. Fuels for construction equipment and hazardous substances which will be used during construction:

The following fuels and/or hazardous substances will be stored on the site: diesel and miscellaneous oils.

These fuels and/or hazardous substances will be stored in:

- Aboveground storage tanks with a cumulative storage capacity of less than 250 gallons will be stored on the site for less than one (1) year.
  - Aboveground storage tanks with a cumulative storage capacity between 250 gallons and 499 gallons will be stored on the site for less than one (1) year.
  - Aboveground storage tanks with a cumulative storage capacity of 500 gallons or more will be stored on the site. An Aboveground Storage Tank Facility Plan application must be submitted to the appropriate regional office of the TCEQ prior to moving the tanks onto the project.
- Fuels and hazardous substances will not be stored on the site.
2.  **Attachment A - Spill Response Actions.** A site specific description of the measures to be taken to contain any spill of hydrocarbons or hazardous substances is attached.
  3.  Temporary aboveground storage tank systems of 250 gallons or more cumulative storage capacity must be located a minimum horizontal distance of 150 feet from any domestic, industrial, irrigation, or public water supply well, or other sensitive feature.
  4.  **Attachment B - Potential Sources of Contamination.** A description of any activities or processes which may be a potential source of contamination affecting surface water quality is attached.

### ***Sequence of Construction***

5.  **Attachment C - Sequence of Major Activities.** A description of the sequence of major activities which will disturb soils for major portions of the site (grubbing, excavation, grading, utilities, and infrastructure installation) is attached. **N/A**
  - For each activity described, an estimate (in acres) of the total area of the site to be disturbed by each activity is given.
  - For each activity described, include a description of appropriate temporary control measures and the general timing (or sequence) during the construction process that the measures will be implemented.
6.  Name the receiving water(s) at or near the site which will be disturbed or which will receive discharges from disturbed areas of the project:

### ***Temporary Best Management Practices (TBMPs)***

*Erosion control examples: tree protection, interceptor swales, level spreaders, outlet stabilization, blankets or matting, mulch, and sod. Sediment control examples: stabilized construction exit, silt fence, filter dikes, rock berms, buffer strips, sediment traps, and sediment basins. Please refer to the Technical Guidance Manual for guidelines and specifications. All structural BMPs must be shown on the site plan.*

7.  **Attachment D – Temporary Best Management Practices and Measures.** TBMPs and measures will prevent pollution of surface water, groundwater, and stormwater. The construction-phase BMPs for erosion and sediment controls have been designed to retain sediment on site to the extent practicable. **N/A**

8. The following information is attached: **N/A**

- A description of how BMPs and measures will prevent pollution of surface water, groundwater or stormwater that originates upgradient from the site and flows across the site.
- A description of how BMPs and measures will prevent pollution of surface water or groundwater that originates on-site or flows off site, including pollution caused by contaminated stormwater runoff from the site.
- A description of how BMPs and measures will prevent pollutants from entering surface streams, sensitive features, or the aquifer.
- A description of how, to the maximum extent practicable, BMPs and measures will maintain flow to naturally-occurring sensitive features identified in either the geologic assessment, TCEQ inspections, or during excavation, blasting, or construction.

9.  The temporary sealing of a naturally-occurring sensitive feature which accepts recharge to the Edwards Aquifer as a temporary pollution abatement measure during active construction should be avoided.

**Attachment E - Request to Temporarily Seal a Feature.** A request to temporarily seal a feature is attached. The request includes justification as to why no reasonable and practicable alternative exists for each feature.

There will be no temporary sealing of naturally-occurring sensitive features on the site.

10.  **Attachment F - Structural Practices.** A description of the structural practices that will be used to divert flows away from exposed soils, to store flows, or to otherwise limit runoff discharge of pollutants from exposed areas of the site is attached. Placement of structural practices in floodplains has been avoided. **N/A**

11.  **Attachment G - Drainage Area Map.** A drainage area map supporting the following requirements is attached: **N/A**

For areas that will have more than 10 acres within a common drainage area disturbed at one time, a sediment basin will be provided.

For areas that will have more than 10 acres within a common drainage area disturbed at one time, a smaller sediment basin and/or sediment trap(s) will be used.

For areas that will have more than 10 acres within a common drainage area disturbed at one time, a sediment basin or other equivalent controls are not attainable, but other TBMPs and measures will be used in combination to protect down slope and side slope boundaries of the construction area.

There are no areas greater than 10 acres within a common drainage area that will be disturbed at one time. A smaller sediment basin and/or sediment trap(s) will be used in combination with other erosion and sediment controls within each disturbed drainage area.

- There are no areas greater than 10 acres within a common drainage area that will be disturbed at one time. Erosion and sediment controls other than sediment basins or sediment traps within each disturbed drainage area will be used.
12.  **Attachment H - Temporary Sediment Pond(s) Plans and Calculations.** Temporary sediment pond or basin construction plans and design calculations for a proposed temporary BMP or measure have been prepared by or under the direct supervision of a Texas Licensed Professional Engineer. All construction plans and design information must be signed, sealed, and dated by the Texas Licensed Professional Engineer. Construction plans for the proposed temporary BMPs and measures are attached.
- N/A
13.  **Attachment I - Inspection and Maintenance for BMPs.** A plan for the inspection of each temporary BMP(s) and measure(s) and for their timely maintenance, repairs, and, if necessary, retrofit is attached. A description of the documentation procedures, recordkeeping practices, and inspection frequency are included in the plan and are specific to the site and/or BMP. **N/A**
14.  All control measures must be properly selected, installed, and maintained in accordance with the manufacturer's specifications and good engineering practices. If periodic inspections by the applicant or the executive director, or other information indicate a control has been used inappropriately, or incorrectly, the applicant must replace or modify the control for site situations. **N/A**
15.  If sediment escapes the construction site, off-site accumulations of sediment must be removed at a frequency sufficient to minimize offsite impacts to water quality (e.g., fugitive sediment in street being washed into surface streams or sensitive features by the next rain). **N/A**
16.  Sediment must be removed from sediment traps or sedimentation ponds not later than when design capacity has been reduced by 50%. A permanent stake will be provided that can indicate when the sediment occupies 50% of the basin volume. **N/A**
17.  Litter, construction debris, and construction chemicals exposed to stormwater shall be prevented from becoming a pollutant source for stormwater discharges (e.g., screening outfalls, picked up daily).

### ***Soil Stabilization Practices***

*Examples: establishment of temporary vegetation, establishment of permanent vegetation, mulching, geotextiles, sod stabilization, vegetative buffer strips, protection of trees, or preservation of mature vegetation.*

18.  **Attachment J - Schedule of Interim and Permanent Soil Stabilization Practices.** A schedule of the interim and permanent soil stabilization practices for the site is attached. **N/A**

19.  Records must be kept at the site of the dates when major grading activities occur, the dates when construction activities temporarily or permanently cease on a portion of the site, and the dates when stabilization measures are initiated. **N/A**
20.  Stabilization practices must be initiated as soon as practicable where construction activities have temporarily or permanently ceased. **N/A**

### ***Administrative Information***

21.  All structural controls will be inspected and maintained according to the submitted and approved operation and maintenance plan for the project. **N/A**
22.  If any geologic or manmade features, such as caves, faults, sinkholes, etc., are discovered, all regulated activities near the feature will be immediately suspended. The appropriate TCEQ Regional Office shall be immediately notified. Regulated activities must cease and not continue until the TCEQ has reviewed and approved the methods proposed to protect the aquifer from any adverse impacts.
23.  Silt fences, diversion berms, and other temporary erosion and sediment controls will be constructed and maintained as appropriate to prevent pollutants from entering sensitive features discovered during construction. **N/A**

**Ranger Excavating, LP  
Rattlesnake Ranch Quarry**

**Temporary Stormwater Section (TCEQ-0602)  
Attachment A**

**Spill Response Actions**

**Education**

- (1) Be aware that different materials pollute in different amounts. Make sure that each employee knows what a “significant spill” is for each material they use, and what is the appropriate response for “significant” and “insignificant” spills. Employees should also be aware of when spill must be reported to the TCEQ.
- (2) Educate employees and subcontractors on potential dangers to humans and the environment from spills and leaks.
- (3) Hold regular meetings to discuss and reinforce appropriate disposal procedures (incorporate into regular safety meetings).
- (4) Establish a continuing education program to indoctrinate new employees.
- (5) Have contractor’s superintendent or representative oversee and enforce proper spill prevention and control measures.

**General Measures**

- (1) To the extent that the work can be accomplished safely, spills of oil, petroleum products, substances listed under 40 CFR parts 110,117, and 302, and sanitary and septic wastes should be contained and cleaned up immediately.
- (2) Store hazardous materials and wastes in covered containers and protect from vandalism.
- (3) Place a stockpile of spill cleanup materials where it will be readily accessible.
- (4) Train employees in spill prevention and cleanup.
- (5) Designate responsible individuals to oversee and enforce control measures.
- (6) Spills should be covered and protected from stormwater run on during rainfall to the extent that it doesn’t compromise clean up activities.
- (7) Do not bury or wash spills with water.
- (8) Store and dispose of used clean up materials, contaminated materials, and recovered spill material that is no longer suitable for the intended purpose in conformance with the provisions in applicable BMPs.

**Ranger Excavating, LP**  
**Rattlesnake Ranch Quarry**

(9) Do not allow water used for cleaning and decontamination to enter storm drains or watercourses. Collect and dispose of contaminated water in accordance with applicable regulations.

(10) Contain water overflow or minor water spillage and do not allow it to discharge into drainage facilities or watercourses.

(11) Place Safety Data Sheets (SDS), as well as proper storage, cleanup, and spill reporting instructions for hazardous materials stored or used on the project site in an open, conspicuous, and accessible location.

(12) Keep waste storage areas clean, well-organized, and equipped with ample cleanup supplies as appropriate for the materials being stored. Perimeter controls, containment structures, covers, and liners should be repaired or replaced as needed to maintain proper function.

**Cleanup**

(1) Clean up leaks and spills immediately.

(2) Any spills from an AST facility must be removed from the controlled drainage area for disposal within 24 hours of the spill.

(3) Use a rag for small spills on paved surfaces, a damp mop for general cleanup, and absorbent material for larger spills. If the spilled material is hazardous, then the used cleanup materials are also hazardous and must be disposed of as hazardous waste.

(4) Never hose down or bury dry material spills. Clean up as much of the material as possible and dispose of properly. See the waste management BMPs in this section for specific information.

**Minor Spills**

(1) Minor spills typically involve small quantities of oil, gasoline, paint, etc. which can be controlled by the first responder at the discovery of the spill.

(2) Use absorbent materials on small spills rather than hosing down or burying the spill.

(3) Absorbent materials should be promptly removed and disposed of properly.

(4) Follow the practice below for a minor spill:

(5) Contain the spread of the spill.



**Ranger Excavating, LP  
Rattlesnake Ranch Quarry**

(6) Recover spilled materials.

(7) Clean the contaminated area and properly dispose of contaminated materials.

**Semi-Significant Spills**

Semi-significant spills still can be controlled by the first responder along with the aid of other personnel such as laborers and the foreman, etc. This response may require the cessation of all other activities.

Spills should be cleaned up immediately:

(1) Contain spread of the spill.

(2) Notify the project foreman as soon as possible.

(3) If the spill occurs on paved or impermeable surfaces, clean up using "dry" methods (absorbent materials, cat litter and/or rags). Contain the spill by encircling with absorbent materials and do not let the spill spread widely.

(4) If the spill occurs in dirt areas, as soon as possible contain the spill by constructing an earthen dike. Dig up and properly dispose of contaminated soil.

(5) If the spill occurs during rain, cover spill with tarps or other material to prevent contaminating runoff.

**Significant/Hazardous Spills**

For significant or hazardous spills that are in reportable quantities:

(1) Notify the TCEQ by telephone as soon as possible and within 24 hours at 512-339-2929 (Austin) or 210-490-3096 (San Antonio) between 8 AM and 5 PM. After hours, contact the Environmental Release Hotline at 1-800-832-8224. It is the contractor's responsibility to have all emergency phone numbers at the construction site.

(2) For spills of federal reportable quantities, in conformance with the requirements in 40 CFR parts 110,119, and 302, the contractor should notify the National Response Center at (800) 424-8802.

(3) Notification should first be made by telephone and followed up with a written report.

(4) The services of a spills contractor or a Haz-Mat team should be obtained as soon as possible. Construction personnel should not attempt to clean up until the appropriate and qualified staffs have arrived at the job site.

**Ranger Excavating, LP  
Rattlesnake Ranch Quarry**

(5) Other agencies which may need to be consulted include, but are not limited to, the City Police Department, County Sheriff Office, Fire Departments, etc.

In the event of a reportable spill, the following Emergency Response Agencies can be contacted for assistance. Always inform your supervisor of a reportable spill as soon as possible. Follow company policy when responding to an emergency.

State Emergency Response Commission	(512) 463-7727
National Response Center	(800) 424-8802
US EPA Region 6, Dallas, 24-hr Number	(866) 372-7745
National Weather Service	(281) 337-5074
TCEQ 24-hr	(800) 832-8224
TCEQ Region 11 Austin Office	(512) 339-2929

**Vehicle and Equipment Fueling**

- (1) If fueling must occur on site, use designated areas, located away from drainage courses, to prevent the run-on of stormwater and the runoff of spills.
- (2) Discourage “topping off” of fuel tanks.
- (3) Always use secondary containment, such as a drain pan, when fueling to catch spills/ leaks.
- (4) Fueling will occur over the impervious concrete slab. Drain pans, curbing and sumps will be used to control spills from fueling.

**Portable Toilet BMPs:**

If portable toilets are used at this site, they will be handled in accordance with the following guidelines:

- A licensed waste collector should service all the toilets. **The following tasks will be performed by the portable toilet supplier:**
  - Empty portable toilets before transporting them.
  - Securely fasten the toilets to the transport truck.
  - Use hand trucks, dollies, and power tailgates whenever possible.
  - Suppliers should carry bleach for disinfection in the event of a spill or leak.
  - Inspect the toilets frequently for leaks and have the units serviced and sanitized at time intervals that will maintain sanitary conditions of each toilet.
- Locate portable toilets at least 20 feet from the nearest storm-drain inlet or sensitive-feature filter strip area
- A berm will be constructed around all portable toilet facilities.
- Prepare a level ground surface with clear access to the toilets.

Secure all portable toilets to prevent tipping by accident, weather, or vandalism.

**Ranger Excavating, LP  
Rattlesnake Ranch Quarry**

Sewage pump-out tanks may be associated with modular or trailer-style buildings (i.e. – plant office, scale house, etc.). These tanks operate with the same nature and character as the portable toilets: they temporarily hold sewage from modular building restrooms and will be serviced by the same contractor, in the same way, as portable toilets. These tanks may be partially or fully buried but are still considered temporary/portable as they are intended to be repositioned on site over time to meet operational needs, and therefore do not constitute an OSSF or holding tank as defined by 30 TAC 285, nor any other type of organized sewage collection system.

**Ranger Excavating, LP  
Rattlesnake Ranch Quarry**

**DETAILED TELEPHONE SPILL REPORT FORM**

Date of Incident: \_\_\_\_\_

Location of Incident: \_\_\_\_\_

Description of material spilled: \_\_\_\_\_

Quantity of material spilled: \_\_\_\_\_

Cause of spill: \_\_\_\_\_

Authorities notified: \_\_\_\_\_

Remediation/clean-up action: \_\_\_\_\_

\_\_\_\_\_

\_\_\_\_\_

\_\_\_\_\_

Corrective measures taken for prevention of reoccurrence: \_\_\_\_\_

\_\_\_\_\_

\_\_\_\_\_

\_\_\_\_\_

Signature: \_\_\_\_\_

Notes: \_\_\_\_\_

\_\_\_\_\_

\_\_\_\_\_

\_\_\_\_\_

Emergency Number for the National Response Center 1-800-424-8802



**Ranger Excavating, LP  
Rattlesnake Ranch Quarry**

**Temporary Stormwater Section (TCEQ-0602)  
Attachment B**

**Potential Sources of Contamination**

Potential sources of contamination in the project area are soil, fuels and lubricants from vehicles and equipment, and trash/debris items.

**Temporary Stormwater Section (TCEQ-0602)  
Attachments C, D, E, F, G, H, I, and J**

The Temporary Stormwater Attachments C, D, E, F, G, H, I, and J are not included with this project; there will be no new disturbance or grading as a result of this plan.

Per the TCEQ's request, to satisfy administrative intake requirements, copies of these attachments from the WPAP Plan submittal have been attached here.

**Ranger Excavating, LP  
Rattlesnake Ranch Quarry**

**Temporary Stormwater Section (TCEQ-0602)**

**Attachments C, D, E, F, G, H, I, and J  
as submitted with WPAP Application  
EAPP ID No. 11003852**

**Ranger Excavating, LP  
Rattlesnake Ranch Quarry**

**Portable Toilet BMPs:**

Portable toilets and/or sewage pump-out tanks will be used on-site and will be handled in accordance with the following guidelines:

- A licensed waste collector should service all the toilets/tanks. **The following tasks will be performed by the portable toilet supplier:**
  - Empty portable toilets/tanks before transporting them.
  - Securely fasten the toilets/tanks to the transport truck.
  - Use hand trucks, dollies, and power tailgates whenever possible.
  - Suppliers should carry bleach for disinfection in the event of a spill or leak.
  - Inspect the toilets frequently for leaks and have the units serviced and sanitized at time intervals that will maintain sanitary conditions of each toilet.
  - Pump-out tanks should be checked periodically for leaks. (Methods may include, but are not limited to: visual inspection, water level monitoring, pump-out volume comparisons, etc.)
- Locate portable toilets at least 20 feet from the nearest storm-drain inlet or sensitive-feature buffer area
- A berm will be constructed around all portable toilet facilities.
- Prepare a level ground surface with clear access to the toilets.
- Secure all portable toilets to prevent tipping by accident, weather, or vandalism.

Sewage pump-out tanks may be associated with modular or trailer-style buildings (i.e. – plant office, scale house, etc.). These tanks operate with the same nature and character as the portable toilets: they temporarily hold sewage from modular building restrooms and will be serviced by the same contractor, in the same way, as portable toilets. These tanks may be partially or fully buried but are still considered temporary/portable as they are intended to be repositioned on site over time to meet operational needs, and therefore do not constitute an OSSF or holding tank as defined by 30 TAC 285, nor any other type of organized sewage collection system.

**Temporary Stormwater Section (TCEQ-0602)  
Attachment B**

**Potential Sources of Contamination**

Potential sources of contamination in the project area are the soil, fuels and lubricants from vehicles and equipment, and trash/debris items.

**Temporary Stormwater Section (TCEQ-0602)  
Attachment C**

**Sequence of Major Activities**

Perimeter earthen berms will be established as shown on the Interim Conditions site plan. Clearing and grubbing will continue for the mining progression in 10-acre or less area increments. The cleared topsoil may be used to construct earthen berms surrounding the cleared area. Berms must be constructed to the height of the highest machine's axle height which will be approximately 2-4 feet high. The earthen berms surrounding the quarry will expand as the quarry expands to the Final Earthen Berm.

**Ranger Excavating, LP  
Rattlesnake Ranch Quarry**

Once mining has commenced for the initial pit, Ranger proposes to construct a new entry road near the Northwestern corner of the property off Old 195. This proposed road will connect from Old 195 and transect East to the proposed office building, maintenance shop, and truck scale as shown in the Final Conditions plan sheet.

**Temporary Stormwater Section (TCEQ-0602)  
Attachment D**

**Temporary Best Management Practices (TBMPs)**

7.a. TBMPs and measures will prevent pollution of surface water, groundwater and stormwater that originates upgradient from the site and flows across the site.

As the incremental quarry area is cleared and topsoil is removed, earthen berms will be constructed. Upgradient berms will direct stormwater runoff around disturbed areas of the site.

As the size of the quarry expands, the earthen berms will expand throughout the life of the project, up to the buffer zones to provide additional controls as mining progresses. Temporary natural existing vegetation will be maintained in a 25-foot buffer along the FEMA 100-year floodplain of the tributaries from Berry Creek. This buffer will be maintained until and unless appropriate permits can be obtained from Williamson County, FEMA and/or USACE to allow construction in the area. In addition, a natural vegetated buffer with a minimum width of 50 feet will be maintained between the Final Earthen Berm and the property line. This natural vegetated buffer will serve as a final buffer for stormwater runoff leaving the active portion of the site.

7.b. TBMPs and measures will prevent pollution of surface water, groundwater and stormwater that originates on-site or flows off site, including pollution caused by contaminated stormwater runoff from the site.

As the incremental quarry area is cleared and topsoil is removed, earthen berms will be constructed. Upgradient berms will direct stormwater runoff around disturbed areas of the site.

Natural existing vegetation will be maintained in a 25-foot buffer along the FEMA 100-year floodplain of the tributary from Berry Creek. This buffer will be maintained until and unless appropriate permits can be obtained from Williamson County, FEMA and/or USACE to allow construction in the area. In addition, a natural vegetated buffer with a minimum width of 50 feet will be maintained between the Final Earthen Berm and the property line. This natural vegetated buffer will serve as a final buffer for stormwater runoff leaving the active portion of the site.

7.c. TBMPs and measures will prevent pollution of surface streams, sensitive features, and the aquifer.

As the size of the quarry expands, the earthen berms will expand throughout the life of the project. Earthen berms and vegetated areas will be constructed/maintained as shown on the attached Interim and Final Conditions plan sheets to prevent pollutants from entering surface streams, sensitive features and the aquifer.



## **Ranger Excavating, LP Rattlesnake Ranch Quarry**

Temporary natural existing vegetation will be maintained in a 25-foot buffer on both sides from the centerline of the unnamed tributary of Berry Creek. This buffer will be maintained until construction begins in the area. In addition, a natural vegetated buffer with a minimum width of 50-feet will be maintained between the Final Earthen Berm and the property line. This natural vegetated buffer will serve as a final buffer for stormwater runoff leaving the active portion of the site. No sensitive features were identified on-site.

7.d. To the maximum extent practicable TBMPs and measures will maintain flow to naturally occurring sensitive features identified in the geologic assessment, TCEQ inspections, or during excavation, blasting, or construction.

A geologic assessment has been completed for the proposed ~163-acre site and is included with this application. None of the karst features on site were identified as sensitive. All identified features will eventually be removed through mining.

Ranger Excavating, LP will provide initial feature recognition training to mining staff within 90 days of approval of this WPAP application. Initial feature recognition training will also be provided to applicable new employees (site supervisors and quarry operators) within 90 days of hire. Refresher training will be provided to quarry operators as needed. All training will be conducted by the Site Supervisor or his designee using a training program prepared by a PG.

The site supervisor or his designee will maintain records of when features are identified by mining staff. These records will include the date the feature was identified, the general location of the feature, a general description of the feature, and what action was taken regarding the potential feature. These records will be maintained for five years and will be made available to the TCEQ upon request.

Any possibly sensitive geologic feature discovered by mining staff will be handled in the following manner: Sediment that can be easily removed from the area adjacent to the feature without disturbing the feature will be removed. Then a rock berm will be placed around the feature to control and filter any potential flow into the feature. After placement of the rock berm, the active work area of the quarry will be moved to another portion of the pit where the feature cannot be impacted by the continuing quarry operations. A Professional Geologist will be called to the site to assess and rate the feature. If the feature is determined to be sensitive in accordance with TAC 213 rules, the TCEQ will be notified and an appropriate method for addressing the feature will be formulated and submitted for TCEQ approval. Work will not resume in the area of the feature until the TCEQ approved method for addressing the feature has been carried out.

**Ranger Excavating, LP  
Rattlesnake Ranch Quarry**

**Temporary Stormwater Section (TCEQ-0602)  
Attachment E**

**Request to Temporarily Seal a Feature**

The Temporary Stormwater attachment E is not applicable for this project.

**Temporary Stormwater Section (TCEQ-0602)  
Attachment F**

**Structural Practices**

Structural practices such as compacted earthen berms, rock berms and natural vegetation areas will be utilized as necessary to control stormwater from Site during mine related activities and continued operations at the Site after all mining related activities are complete. The compacted earthen berms will be used to contain and limit runoff discharge of pollutants from exposed areas of the Site as well as to divert flows away from exposed (disturbed) soils.

**Temporary Stormwater Section (TCEQ-0602)  
Attachment G**

**Drainage Area Map**

Please see Interim Conditions Plan Sheet.

**Temporary Stormwater Section (TCEQ-0602)  
Attachment H**

The Temporary Stormwater attachment H is not applicable for this project.

**Ranger Excavating, LP  
Rattlesnake Ranch Quarry**

**Temporary Stormwater Section (TCEQ-0602)  
Attachment I**

**Inspection and Maintenance for BMPs**

The compacted earthen berms should be inspected quarterly. All rock berms and silt fences should be inspected weekly. Written documentation of these inspections should be kept during construction at the project site (see following example Inspection Form). Any erosion of earthen berms or rock berms should be backfilled and compacted as soon as possible. If a berm is no longer able to properly filter the sediment from the stormwater due to contamination from silt, it should be replaced. Any trash in the vegetated buffers should be removed and eroded areas should be reseeded. Silt fencing should be repaired or replaced when damaged and sediment should be removed when buildup reaches 6 inches.

The site will be authorized to discharge stormwater under the TPDES General Permit No. TXR050000 for industrial activities. Requirements of the general permit include maintaining a SWP3 which includes inspections of stormwater best management practices and sampling of stormwater that is discharged from the site. Trash and construction debris should not become a potential pollutant source for stormwater discharge and should be removed daily. Should any vegetative areas be eroded, they must be reseeded.

It is not anticipated that dewatering of the pit will be required. However, if necessary, mine dewatering will be accomplished according to the TCEQ stormwater regulations noted in the TPDES General Permit No. TXR050000 under Sector J for Mineral Mining and Processing Facilities.



**Ranger Excavating, LP  
Rattlesnake Ranch Quarry**

**Temporary Stormwater Section (TCEQ-0602)  
Attachment J**

**Schedule of Soil Stabilization Practices**

**Areas Outside the Pit:**

Cleared areas and interim earthen berms may be disturbed for more than 14 days without stabilization because it is not practical to be continually stabilizing small areas prior to their excavation and stabilizing the earthen berms that are frequently relocated. The purpose of soil stabilization is to control erosion and prevent pollutants from entering surface waters, streams, and the aquifer through sensitive recharge features. Areas outside of the pit that are disturbed for quarrying are often drilled and blasted within 90 days. It is not feasible or appropriate to try to stabilize these areas with vegetation because 1) the topsoil has been removed and vegetation will not readily grow; 2) these areas will soon be excavated and; 3) other structural BMPs will be used to protect stormwater runoff quality from these areas in a manner consistent with customary and acceptable mining practices.

Because the soils and overburden in these cleared areas have been removed and placed in an earthen berm adjacent to the cleared areas, erosion of these areas is mitigated. The earthen berms upgradient of the cleared areas divert upgradient stormwater away from cleared areas and earthen berms and/or sediment basins downgradient of cleared areas will treat and/or retain stormwater runoff from the cleared area. The proposed BMPs provide adequate protection for the area outside of the pit.

Material stockpiles will be located within the quarry pit and earthen berms.

For the case when the quarry operations have been completed (permanently ceased) all stormwater will be retained in the pit. The Final Earthen Berm outside the pit will be stabilized with native grasses. The undisturbed vegetated buffers shown on the Final Conditions plan sheet will remain undisturbed so no additional stabilization practices will be needed.

**Areas Inside the Pit:**

Areas inside the pit do not need to be stabilized; the requirement for soil stabilization exists in order to control erosion and prevent pollutants from entering surface waters, streams and the aquifer through sensitive recharge features. The disturbed soils in or upgradient of the quarry pit will be retained in the pit thereby eliminating the need for soil stabilization in the pit to prevent pollutants from entering surface waters or streams. The BMP discussed in the WPAP Temporary Stormwater Section Attachment D (7.d.) will mitigate infiltration of stormwater into the quarry floor. In addition, it is not practical to stabilize areas of the pit with vegetation because often times areas of the pit will not be active for some period of time, then be reactivated. Therefore, since the disturbed areas will be located in the pit no soil stabilization is expected to be necessary at the completion of the project.





TCEQ Use Only

# TCEQ Core Data Form

For detailed instructions on completing this form, please read the Core Data Form Instructions or call 512-239-5175.

## SECTION I: General Information

<b>1. Reason for Submission</b> (If other is checked please describe in space provided.)		
<input checked="" type="checkbox"/> New Permit, Registration or Authorization (Core Data Form should be submitted with the program application.)		
<input type="checkbox"/> Renewal (Core Data Form should be submitted with the renewal form)	<input type="checkbox"/> Other	
<b>2. Customer Reference Number</b> (if issued)	<a href="#">Follow this link to search for CN or RN numbers in Central Registry**</a>	<b>3. Regulated Entity Reference Number</b> (if issued)
CN 602783037		RN 111875878

## SECTION II: Customer Information

<b>4. General Customer Information</b>		<b>5. Effective Date for Customer Information Updates</b> (mm/dd/yyyy)	
<input type="checkbox"/> New Customer		<input type="checkbox"/> Update to Customer Information	
<input type="checkbox"/> Change in Legal Name (Verifiable with the Texas Secretary of State or Texas Comptroller of Public Accounts)		<input type="checkbox"/> Change in Regulated Entity Ownership	
<i>The Customer Name submitted here may be updated automatically based on what is current and active with the Texas Secretary of State (SOS) or Texas Comptroller of Public Accounts (CPA).</i>			
<b>6. Customer Legal Name</b> (If an individual, print last name first: eg: Doe, John)		<i>If new Customer, enter previous Customer below:</i>	
Ranger Excavating, LP			
<b>7. TX SOS/CPA Filing Number</b>	<b>8. TX State Tax ID</b> (11 digits)	<b>9. Federal Tax ID</b> (9 digits)	<b>10. DUNS Number</b> (if applicable)
0800280937	13310779817		
<b>11. Type of Customer:</b>	<input checked="" type="checkbox"/> Corporation	<input type="checkbox"/> Individual	Partnership: <input type="checkbox"/> General <input type="checkbox"/> Limited
Government: <input type="checkbox"/> City <input type="checkbox"/> County <input type="checkbox"/> Federal <input type="checkbox"/> Local <input type="checkbox"/> State <input type="checkbox"/> Other	<input type="checkbox"/> Sole Proprietorship	<input type="checkbox"/> Other:	
<b>12. Number of Employees</b>	<b>13. Independently Owned and Operated?</b>		
<input type="checkbox"/> 0-20 <input checked="" type="checkbox"/> 21-100 <input type="checkbox"/> 101-250 <input type="checkbox"/> 251-500 <input type="checkbox"/> 501 and higher	<input type="checkbox"/> Yes <input checked="" type="checkbox"/> No		
<b>14. Customer Role</b> (Proposed or Actual) – as it relates to the Regulated Entity listed on this form. Please check one of the following			
<input type="checkbox"/> Owner <input type="checkbox"/> Operator <input checked="" type="checkbox"/> Owner & Operator <input type="checkbox"/> Other:			
<input type="checkbox"/> Occupational Licensee <input type="checkbox"/> Responsible Party <input type="checkbox"/> VCP/BSA Applicant			
<b>15. Mailing Address:</b>	5222 Thunder Creek Rd, Suite B-1		
	City	Austin	State TX ZIP 78759 ZIP + 4
<b>16. Country Mailing Information</b> (if outside USA)		<b>17. E-Mail Address</b> (if applicable)	
		hamilton.mcrae@austingeologic.com	
<b>18. Telephone Number</b>	<b>19. Extension or Code</b>	<b>20. Fax Number</b> (if applicable)	
(512) 331-5551		(512) 343-9618	

## SECTION III: Regulated Entity Information

<b>21. General Regulated Entity Information</b> (If 'New Regulated Entity' is selected, a new permit application is also required.)
<input type="checkbox"/> New Regulated Entity <input type="checkbox"/> Update to Regulated Entity Name <input type="checkbox"/> Update to Regulated Entity Information
<i>The Regulated Entity Name submitted may be updated, in order to meet TCEQ Core Data Standards (removal of organizational endings such as Inc, LP, or LLC).</i>
<b>22. Regulated Entity Name</b> (Enter name of the site where the regulated action is taking place.)
Rattlesnake Ranch Quarry

23. Street Address of the Regulated Entity: <i>(No PO Boxes)</i>	8880 Old 195						
	City	Florence	State	TX	ZIP	76527	ZIP + 4
24. County	Williamson						

If no Street Address is provided, fields 25-28 are required.

25. Description to Physical Location:							
26. Nearest City	Florence			State	TX	Nearest ZIP Code	76527
<i>Latitude/Longitude are required and may be added/updated to meet TCEQ Core Data Standards. (Geocoding of the Physical Address may be used to supply coordinates where none have been provided or to gain accuracy).</i>							
27. Latitude (N) In Decimal:	30.788550°			28. Longitude (W) In Decimal:	-97.761379°		
Degrees	Minutes	Seconds	Degrees	Minutes	Seconds		
30	47	18.78	97	45	40.96		
29. Primary SIC Code (4 digits)	1442	30. Secondary SIC Code (4 digits)		31. Primary NAICS Code (5 or 6 digits)		32. Secondary NAICS Code (5 or 6 digits)	
33. What is the Primary Business of this entity? <i>(Do not repeat the SIC or NAICS description.)</i>							
Construction Materials							
34. Mailing Address:	5222 Thunder Creek Rd, Suite B-1						
	City	Austin	State	TX	ZIP	78759	ZIP + 4
35. E-Mail Address:	hamilton.mcrae@austingeologic.com						
36. Telephone Number	(512) 331-5551	37. Extension or Code		38. Fax Number <i>(if applicable)</i>	(512) 343-9618		

39. TCEQ Programs and ID Numbers Check all Programs and write in the permits/registration numbers that will be affected by the updates submitted on this form. See the Core Data Form instructions for additional guidance.

<input type="checkbox"/> Dam Safety	<input type="checkbox"/> Districts	<input checked="" type="checkbox"/> Edwards Aquifer	<input type="checkbox"/> Emissions Inventory Air	<input type="checkbox"/> Industrial Hazardous Waste
		New AST Plan		
<input type="checkbox"/> Municipal Solid Waste	<input type="checkbox"/> New Source Review Air	<input type="checkbox"/> OSSF	<input type="checkbox"/> Petroleum Storage Tank	<input type="checkbox"/> PWS
<input type="checkbox"/> Sludge	<input type="checkbox"/> Storm Water	<input type="checkbox"/> Title V Air	<input type="checkbox"/> Tires	<input type="checkbox"/> Used Oil
<input type="checkbox"/> Voluntary Cleanup	<input type="checkbox"/> Wastewater	<input type="checkbox"/> Wastewater Agriculture	<input type="checkbox"/> Water Rights	<input type="checkbox"/> Other:

### SECTION IV: Preparer Information

40. Name:	Andrea Kidd, P.E.	41. Title:	Project Engineer
42. Telephone Number	43. Ext./Code	44. Fax Number	45. E-Mail Address
(830) 249-8284		(830) 249-0221	akidd@westwardenv.com

### SECTION V: Authorized Signature

46. By my signature below, I certify, to the best of my knowledge, that the information provided in this form is true and complete, and that I have signature authority to submit this form on behalf of the entity specified in Section II, Field 6 and/or as required for the updates to the ID numbers identified in field 39.

Company:	Ranger Excavating, LP	Job Title:	Engineer
Name <i>(In Print)</i> :	Hamilton McRae	Phone:	(512) 331-5551
Signature:		Date:	1/30/2024



**Agent Authorization Form**  
For Required Signature  
Edwards Aquifer Protection Program  
Relating to 30 TAC Chapter 213  
Effective June 1, 1999

I \_\_\_\_\_ Hamilton McRae, PE  
Print Name

\_\_\_\_\_ Engineer  
Title - Owner/President/Other

of \_\_\_\_\_ Ranger Excavating, LP  
Corporation/Partnership/Entity Name

have authorized \_\_\_\_\_ Curt G. Campbell, PE; Doug Millsaps, PE; Vance Houy, PE;  
Gary D. Nicholls, PE; Andrea Kidd, PE; and Nicolas Mercado, PE, Chelsy L. Houy, PE  
Print Name of Agent/Engineer

of \_\_\_\_\_ Westward Environmental, Inc  
Print Name of Firm

to represent and act on the behalf of the above named Corporation, Partnership, or Entity for the purpose of preparing and submitting this plan application to the Texas Commission on Environmental Quality (TCEQ) for the review and approval consideration of regulated activities.

I also understand that:

1. The applicant is responsible for compliance with 30 Texas Administrative Code Chapter 213 and any condition of the TCEQ's approval letter. The TCEQ is authorized to assess administrative penalties of up to \$10,000 per day per violation.
2. For those submitting an application who are not the property owner, but who have the right to control and possess the property, additional authorization is required from the owner.
3. Application fees are due and payable at the time the application is submitted. The application fee must be sent to the TCEQ cashier or to the appropriate regional office. The application will not be considered until the correct fee is received by the commission.
4. A notarized copy of the Agent Authorization Form must be provided for the person preparing the application, and this form must accompany the completed application.
5. No person shall commence any regulated activity on the Edwards Aquifer Recharge Zone, Contributing Zone or Transition Zone until the appropriate application for the activity has been filed with and approved by the Executive Director.



# Application Fee Form

## Texas Commission on Environmental Quality

Name of Proposed Regulated Entity: Rattlesnake Ranch Quarry

Regulated Entity Location: 8880 Old 195, Florence, TX 76527

Name of Customer: Ranger Excavating, LP

Contact Person: Hamilton McRae

Phone: (512) 372-0734

Customer Reference Number (if issued): CN 602783037

Regulated Entity Reference Number (if issued): RN 111875878

### Austin Regional Office (3373)

Hays

Travis

Williamson

### San Antonio Regional Office (3362)

Bexar

Medina

Uvalde

Comal

Kinney

Application fees must be paid by check, certified check, or money order, payable to the **Texas Commission on Environmental Quality**. Your canceled check will serve as your receipt. **This form must be submitted with your fee payment.** This payment is being submitted to:

Austin Regional Office

San Antonio Regional Office

Mailed to: TCEQ - Cashier ePay

Overnight Delivery to: TCEQ - Cashier

Revenues Section

Mail Code 214

P.O. Box 13088

Austin, TX 78711-3088

12100 Park 35 Circle

Building A, 3rd Floor

Austin, TX 78753

(512)239-0357

### Site Location (Check All That Apply):

Recharge Zone

Contributing Zone

Transition Zone

<i>Type of Plan</i>	<i>Size</i>	<i>Fee Due</i>
Water Pollution Abatement Plan, Contributing Zone Plan: One Single Family Residential Dwelling	Acres	\$
Water Pollution Abatement Plan, Contributing Zone Plan: Multiple Single Family Residential and Parks	Acres	\$
Water Pollution Abatement Plan, Contributing Zone Plan: Non-residential	Acres	\$
Sewage Collection System	L.F.	\$
Lift Stations without sewer lines	Acres	\$
Underground or Aboveground Storage Tank Facility	6 Tanks	\$ 3900
Piping System(s)(only)	Each	\$
Exception	Each	\$
Extension of Time	Each	\$

Signature: 

Date: 1/30/2024

# Application Fee Schedule

Texas Commission on Environmental Quality

Edwards Aquifer Protection Program 30 TAC Chapter 213 (effective 05/01/2008)

## **Water Pollution Abatement Plans and Modifications**

### **Contributing Zone Plans and Modifications**

<b>Project</b>	<b>Project Area in Acres</b>	<b>Fee</b>
One Single Family Residential Dwelling	< 5	\$650
Multiple Single Family Residential and Parks	< 5	\$1,500
	5 < 10	\$3,000
	10 < 40	\$4,000
	40 < 100	\$6,500
	100 < 500	\$8,000
	≥ 500	\$10,000
Non-residential (Commercial, industrial, institutional, multi-family residential, schools, and other sites where regulated activities will occur)	< 1	\$3,000
	1 < 5	\$4,000
	5 < 10	\$5,000
	10 < 40	\$6,500
	40 < 100	\$8,000
	≥ 100	\$10,000

### **Organized Sewage Collection Systems and Modifications**

<b>Project</b>	<b>Cost per Linear Foot</b>	<b>Minimum Fee- Maximum Fee</b>
Sewage Collection Systems	\$0.50	\$650 - \$6,500

### **Underground and Aboveground Storage Tank System Facility Plans and Modifications**

<b>Project</b>	<b>Cost per Tank or Piping System</b>	<b>Minimum Fee- Maximum Fee</b>
Underground and Aboveground Storage Tank Facility	\$650	\$650 - \$6,500

### **Exception Requests**

<b>Project</b>	<b>Fee</b>
Exception Request	\$500

### **Extension of Time Requests**

<b>Project</b>	<b>Fee</b>
Extension of Time Request	\$150